

LEGEND

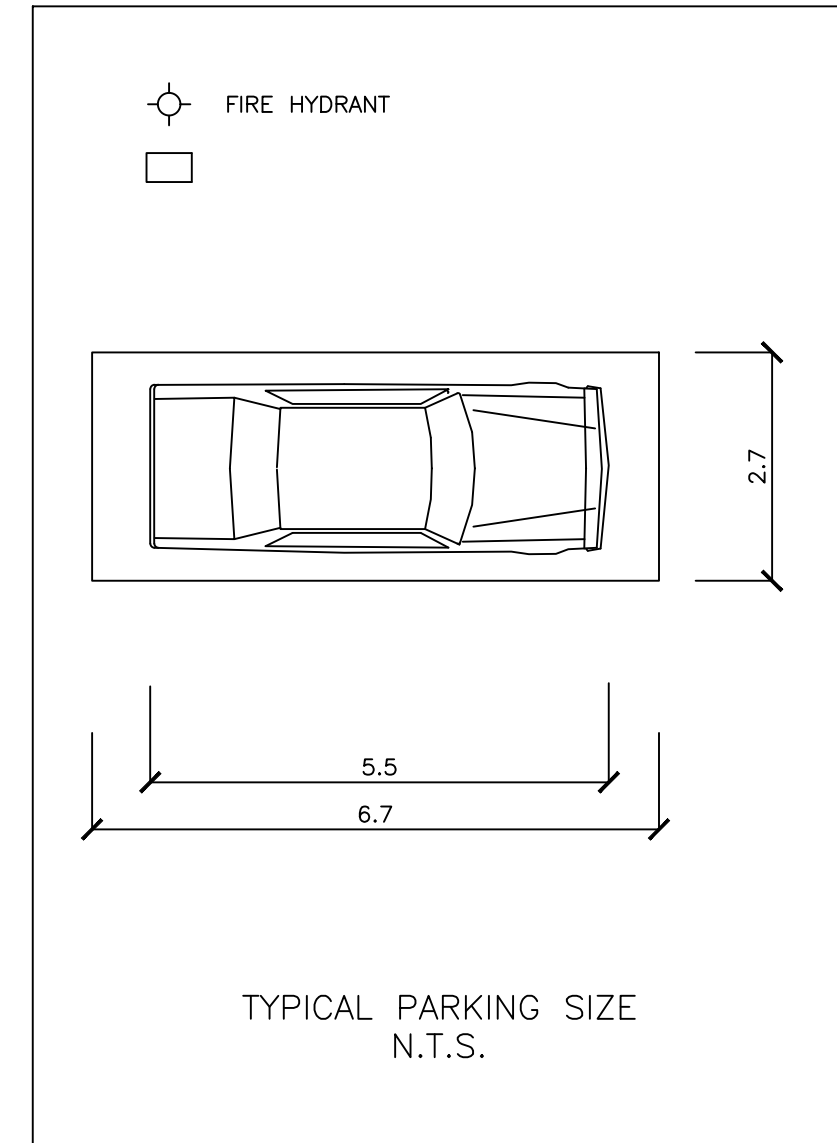

TOTAL NUMBER OF SINGLE FAMILY LOTS = 309  
 TOTAL ON-STREET PARKING PROVIDED = 75

LEGEND

- STOP SIGN (Ra-1)
- NO PARKING ZONE
- NO PARKING SIGN (Rb-51)
- NO PARKING SIGN (Rb-51L)
- NO PARKING SIGN (Rb-51R)
- ▲ CHEVRON SIGN (Wa-9)
- ◆ CHECKERBOARD SIGN (Wa-8LR)
- ▨ CROSSWALK

BLOCK 22A  
 MED. DENSITY RESIDENTIAL



PARKING ALONG WEST SIDE OF HITCHMAN ST. TO BE CONFIRMED IN CONJUNCTION WITH BLOCK 22 SPA

BLOCK 22B  
 MED. DENSITY RESIDENTIAL

BLOCK 31 OPEN SPACE

SHARP CURVE/ADVISORY REDUCED SPEED SIGN & SPACING AHEAD OF POWERLINE/POTTRUFF REALIGNMENT SHALL BE CONFIRMED BY PARADIGM TRANSPORTATION CONSULTING ENGINEERS PRIOR TO CONSTRUCTION PER OTM BOOK 6/TAC MANUAL.

11/22/2023 12:26pm B17-007 - TREE PARKING.DWG

EXISTING SERVICES	DRAWING #, SOURCE	DATE	AS CONSTRUCTED SERVICES	COMPLETION

No.	REVISIONS	DATE	CONSULTANT
1	DESIGN BY: RD/SD		
2	ISSUED FOR TENDR	FEB. 12, 2020	DEVENG
3	ISSUED FOR ADDENDUM NO.2	FEB. 21, 2020	DEVENG
4	ISSUED FOR ECA SIGN-OFF	MAR. 18, 2020	DEVENG
5	ISSUED FOR SECOND SUBMISSION	JUNE 22, 2020	DEVENG
6	ISSUED FOR PRE-SERVICING IFC - PH1	SEPT. 24, 2020	DEVENG
7	ISSUED FOR THIRD SUBMISSION	NOV. 27, 2020	DEVENG
8	ISSUED FOR FOURTH SUBMISSION	JAN. 27, 2021	DEVENG
9	ISSUED FOR FIFTH SUBMISSION	MAR. 04, 2021	DEVENG
10	PER CITY COMMENTS	APR. 04, 2022	DEVENG
11	PER CITY COMMENTS	APR. 11, 2022	DEVENG

CONSULTANT OR DIVISION

London Office  
 41 Adelaide St. N., Unit 71  
 (519) 672-8310

Paris Office  
 31 Mechanic St., Unit 301  
 (519) 442-1441

**development engineering**  
 (London) Limited

CONSULTING CIVIL ENGINEERS

ENGINEER'S STAMP

L.R. MURRAY  
 100142499  
 11 APR '22  
 PROVINCE OF ONTARIO

COUNTY OF Brant Simply Grand

SCALE

SCALE - 1:750

7.5 0 15m

TITLE

**PARIS MEADOWS SUBDIVISION**  
 PARIS ONTARIO, COUNTY OF BRANT  
 KINGWOOD PARIS MEADOWS LTD.

**RESIDENTIAL ON-STREET PARKING, LANE MARKINGS AND SIGNAGE PLAN**

PROJECT No. **B17-007**

SHEET No. **59**

PLAN FILE No.

