

Engineer's Report

TERRYBERRY MUNICIPAL DRAIN IMPROVEMENT 2025

County of Brant



January 29, 2025

To the Mayor and Members of Council of the County of Brant,

Streamline Engineering is pleased to present our accompanying report for the Terryberry Municipal Drain Improvement 2025.

This report recommends the construction of approximately 62m of channel and the improvement of approximately 1,079m of municipal tile drain, including the improvement of four gravel road crossings on Seventh Concession Road.

A summary of the assessments for the project are as follows:

Municipal Lands	\$	35,900
Privately Owned Agricultural – Grantable	\$	274,800
Special Non-Proratable Assessments	\$	125,300
Total Estimated Assessments	\$	436,000

We appreciate the opportunity to provide services to the County of Brant and we trust that this report meets the requirements of the County of Brant.

Respectfully submitted by,

Streamline Engineering Inc.



Trevor Kuepfer, P. Eng.
Project Engineer

Michael Siemon
Civil Technologist

Table of Contents

1	Project Background	1
1.1	Existing Conditions.....	1
1.2	Municipal Drain History	2
1.3	Project Authorization	3
1.4	On-Site Meeting.....	3
1.5	Watershed Area.....	3
2	Design Process and Engineering Considerations	4
2.1	Information Meeting No. 1	4
2.2	Follow up Discussions with Property Owners.....	4
2.3	Design Considerations.....	4
2.4	Environmental Considerations.....	5
3	Proposed Work.....	6
3.1	Recommendations.....	6
3.2	Summary of Work on Each Property.....	6
4	Project Costs.....	7
4.1	Allowances to Property Owners.....	7
4.2	Project Cost Estimate	8
4.3	Assessment Schedules	8
4.4	Grant.....	9
5	Future Considerations.....	10
5.1	Maintenance Costs	10
5.2	Drain Abandonment	10
5.3	Future Maintenance Specifics	10

List of Schedules

Schedule A – Allowances

Schedule B – Project Cost Estimate

Schedule C – Construction Assessments

Schedule D – Maintenance Assessments

Appendices

Appendix A Construction Specifications

Appendix B Drawings

1 Project Background

1.1 Existing Conditions

The existing Terryberry drain is located in the County of Brant, just to the west of Burford ON, and is on Lots 11-12, Concession 6-7. The existing municipal tile is in very poor condition. Many blowouts of the drain were observed and are causing a nuisance for the agricultural operations, particularly on Lot 11 and 12, Concession 6. Further, complaints surrounding this municipal drain system have been noted as early as 1998.



Figure 1 – Tile Blowout of the Terryberry Drain on Agricultural Lands on Lot 11, Concession 6

The drain crosses the Seventh Concession Road in four locations. These crossings include eight concrete structures, six of which were noted to be in very poor condition, being either partially, or completely filled with sediment.



Figure 2 - Existing Concrete Catchbasin Filled with Sediment

The drain outlets into a Provincially Significant Wetland area which flows into Kenny Creek. The existing outlet of the Terryberry drain was observed to be notably lower than the elevation of the channel that it flows into causing it to be submerged with water.

1.2 Municipal Drain History

Streamline Engineering conducted a thorough review of all the historical documentation available in the County of Brant office regarding the Terryberry Municipal Drain as well as for other abutting Municipal Drains. The following is a summary of the drain's history:

- The drain was originally established in 1917.
 - This report established the Main Drain, and Branches A through F which were all tile systems.
- The drain was improved in 1967 under a report by John B. Dodd, O.L.S.
 - This report proposed a full reconstruction of the Main Drain, and Branches A through F of the Terryberry Drain, noting that the existing system was in a state of complete failure.
 - The report provided for over 3 km of tile to be installed, ranging from 8" to 16" in diameter.
 - This report provided for the excavation of approximately 230m of channel to improve the outlet configuration to Kenny Creek.
- Branch E of the Terryberry Drain was improved in 1979 under a report by Karl E. Weslan, P.Eng.
 - This report noted that the tile portion of Branch E was not properly functioning and provided for the excavation of approximately 200m of channel to address this issue.

1.3 Project Authorization

This report has been prepared in response to an appointment by the County of Brant, dated September 24, 2024 to provide an improvement to the Terryberry Municipal Drain in accordance with Section 78 of the Drainage Act, R.S.O. 1990.

A request to improve the drain was completed by staff from the County of Brant in report dated September 17, 2024 (Report #: RPT-0138-24).

1.4 On-Site Meeting

The on-site meeting for this project was held on October 15, 2024 at the intersection of Regional Road 25 and the Seventh Concession Road. The following were present at the meeting.

Dan Bailey	Property Owner
Cindy Martin	Property Representative
Jeff Gulas	Property Owner
Shannon Tweedle	Drainage Superintendent, County of Brant
Braeden Robinson	Engineering Technologist, County of Brant
Michael Siemon	Streamline Engineering
Trevor Kuepfer	Streamline Engineering

It was indicated that there are various blowouts throughout the length of the drain and this has been an ongoing issue for many years. A number of those in attendance at the meeting expressed concern with the water levels in Kenny Creek and the impact on the outlet of the Terryberry Drain.

There was discussion regarding provincially significant wetland areas within the Terryberry drain drainage area. Specifically, the outlet of the drain, as well as some other sporadic lengths of the tile portion of the Terryberry drain were noted to be located in a provincially significant wetland areas. The potential to abandon some portions of the drain within these environmentally sensitive areas that were no longer serving a useful purpose was briefly discussed as well.

1.5 Watershed Area

The total watershed area contributing to the Terryberry drain is approximately 172 acres. The watershed was determined through the examination of topographic contour mapping, the examination of existing drainage reports, and the review of field survey and observations. The watershed area has been adopted as part of this report.

Land use within the watershed area is approximately divided as follows:

- 139 acres as agricultural lands
- 29 acres as woodlot/wetland
- 4 acres as county road right-of-way

2 Design Process and Engineering Considerations

2.1 Information Meeting No. 1

An information meeting for this project was held on November 20th, 2024 at the Burford Community Centre. The following were present at the meeting.

Dan Bailey	Property Owner
Jerry Davis	Property Owner
Cindy Martin	Property Representative
Jeff Gulas	Property Owner
Shannon Tweedle	Drainage Superintendent, County of Brant
Braeden Robinson	Engineering Technologist, County of Brant
Michael Siemon	Streamline Engineering
Cody Kuepfer	Streamline Engineering
Trevor Kuepfer	Streamline Engineering

The watershed boundary, estimated costs, design, allowances and assessments for the recommended improvements were discussed with all of those in attendance. The recommended improvements presented at the meeting included some minor channel works on Lot 12, Concession 6, improvement of the Main Drain, Branch A, Branch, B and Branch C in their entirety to the south limit of the Seventh Concession Road. In addition, it was proposed to abandon a portion of Branch A, as well as the entirety of Branch D and Branch E and utilize the provincially significant wetland area with a newly established outlet point as the connection point for adjacent lands.

Those in attendance inquired about the configuration of the proposed outlet to Kenny Creek, the measures being taken to prevent future drain blowouts, as well as other general questions pertaining to estimated costs. Furthermore, it was questioned if the drain could be realigned slightly in some locations. Streamline Engineering indicated that they would investigate this further, following in the coming months.

2.2 Follow up Discussions with Property Owners

Following the information meeting, Streamline Engineering evaluated and refined the proposed scope of work based on comments from the property owners. The property owners were then contacted to discuss the implications of these adjustments. In addition, Streamline Engineering made an effort to contact all property owners impacted by this project who were not in attendance at either of the previous public meetings.

2.3 Design Considerations

Tile Drain

The tile system has been designed with the Drainage Coefficient Method outlined in the OMAFRA Drainage Guide for Ontario. The drainage coefficient relates to the design capacity of the drainage

system, and is expressed as a depth of water removed from the contributing drainage area, in 24 hours.

For this project an approximate 1 and ½ inch drainage coefficient has been used in the design of the tile drainage system.

Water Quality

This system has been designed to utilize existing wetland areas to attenuate stormwater and improve the quality of the water conveyed by the system.

The proposed system will predominately consist of concrete tiles with geo-textile wrap at each tile joint, designed with very gradual curves to prevent sediment entry into the municipal drainage system. This will greatly reduce the opportunity for soils to enter the municipal drainage system when compared to the existing system with much shorter tile lengths, no geo-textile wrap at the tile joints, and generally meandering alignment. There is anticipated to be a substantial reduction in the amount of sediment conveyed into the downstream watercourse and impacts to agricultural lands due to tile blowouts as a result.

In addition, rip-rap erosion protection is proposed at the outlet of the proposed drain to mitigate erosion along the banks of the receiving channel.

Sufficient Outlet

Section 15 of the Drainage Act requires proposed work be continued to a sufficient outlet which is defined as “a point at which water can be discharged safely so that it will do no damage to lands or roads.” For this project Kenny Creek represents a sufficient outlet for the Terryberry Drain.

2.4 Environmental Considerations

Grand River Conservation Authority, (GRCA)

The GRCA has been apprised of this project throughout its progression and has provided input specific to this project. Their comments were responded to by Streamline Engineering, considered in the proposed works, and the GRCA has indicated that a permit is not required for this project since the project is being completed under the requirements of the Drainage Act.

The Department of Fisheries and Oceans Canada (DFO)

No modifications to an existing channel are proposed as part of this report, only new channel construction. As a result, this project does not require review by DFO.

The Ministry of Environment, Conservation, and Parks (MECP)

There is no indication of any adverse impacts to Species at Risk because of the proposed works.

3 Proposed Work

3.1 Recommendations

Considering topographic survey information, site investigations, design options and their respective costs, environmental constraints, and discussion with involved project stakeholders, Streamline Engineering is of the opinion that the following recommended work best addresses the concerns of the parties affected by the proposed work, while meeting required design constraints.

Streamline Engineering recommends the construction of 62m of channel c/w the installation of erosion and sediment control, and a stilling basin in the open section of the Terryberry Municipal Drain. We also recommend improving approximately 1,025m of Municipal tile drain ranging in diameter from 12" to 30", and eight concrete structures.

Furthermore, we recommend improving four Seventh Concession Road crossings with an approximate total of 54m of plastic pipe ranging in diameter from 12" to 21" c/w surface culvert crossings consisting of an approximate total of 57m of 18" diameter plastic pipe.

This report recommends the abandonment and future considerations for various existing parts of the municipal drainage system as highlighted in Section 5.2 of this report. This report also recommends the incorporation of the wetland areas adjacent to the Main Drain on Lots 11 and 12, Concession 7, and adjacent to Branch A on Lots 10 and 11, Concession 7 into the drainage system to serve as legal outlet points for connecting properties.

3.2 Summary of Work on Each Property

Danny, Janet & Justin Bailey (Roll No. 4-656)

- Construction of a temporary rock check dam;
- Approximately 62m of channel construction;
- Construction of one stilling basin c/w rip-rap erosion protection;
- Stripping of topsoil on agricultural lands and subsequent restoration along route of the drain;
- Installation of approximately 12m of 30" diameter dual-wall plastic pipe;
- Installation of approximately 294m of 30" diameter concrete tile;
- Installation of approximately 154m of 21" diameter concrete tile;
- Installation of approximately 265m of 18" diameter concrete tile;
- Installation of approximately 63m of 12" diameter dual-wall plastic pipe;
- Installation of one concrete junction box;
- Destruction of the existing municipal drain in its entirety;
- Connection of all impacted tiles;
- Tree clearing as required.

Jerome & Wendy Davis (Roll No. 4-658)

- Stripping of topsoil on agricultural lands and subsequent restoration along route of the drain;

- Installation of approximately 159m of 16" diameter concrete tile;
- Installation of approximately 78m of 15" diameter dual-wall plastic pipe;
- Installation of one concrete catchbasin c/w the connection of impacted private drain;
- Connection of all impacted tiles;
- Tree clearing as required.

Seventh Concession Road

- Installation of approximately 18m of 21" diameter dual-wall plastic pipe as part of one road crossing;
- Installation of approximately 36m of 12" diameter dual-wall plastic pipe as a part of two road crossings;
- Installation of approximately 57m of 18" diameter dual-wall plastic pipe as surface culverts as a part of four road crossings;
- Installation of six concrete catch basins c/w the connection of impacted drains;
- Removal and disposal of existing pipe infrastructure in the vicinity of each crossing;
- Restoration of four road crossings to existing conditions or better following pipe installation;

Robert & Scott Bailey (Roll No. 4-420)

- Connection of all impacted tiles.

Hog Farm Van Deelen (Roll No. 4-421)

- Connection of all impacted tiles.

4 Project Costs

4.1 Allowances to Property Owners

For this project allowances have been provided under Sections 29, and 30 of the Drainage Act which are further described below. The allowances for this project are provided in Schedule A of this report.

Section 29 – Right-of-Way (ROW)

For the construction and future maintenance of a drainage system a ROW is required to be established for any party that is required to enter on to private lands. As such, a ROW allowance may be provided for the footprint of a drain, a working space required for the drain, and for any necessary access routes. This allowance compensates property owners to establish such a ROW.

In this report, ROW allowances have been provided as follows:

- A \$5,000 per acre allowance has been provided to establish a working space for lands along the tile portion of the drain.
- All properties with areas designated as wetland proposed to be utilized for the drainage system have been provided an allowance at a rate of \$250 per acre of wetland.
- A \$200 allowance has been provided to all properties where access to the drain may be necessary.

No permanent buildings, structures or plantings should be allowed within the ROW, to allow for future maintenance of the drain.

Section 30 – Damages

The Damage allowance compensates property owners for land damage that may occur during construction and in future maintenance activities. The assumed working corridors for this project are utilized in the Damage allowance calculations and are summarized in the Special Provisions in Appendix A for this project.

In this report, damages have been calculated as follows:

- A \$1,600 per acre allowance has been provided on workable, agricultural lands where crops damage may be necessary during the drain construction.
- A minimum damage allowance of \$200 was provided to properties affected by minor construction activities.

4.2 Project Cost Estimate

The total project cost is estimated to be **\$ 436,000**. This cost includes estimated construction costs, allowances, administrative costs, an allotment for contingency costs, net HST, interest charges, etc. Schedule B – Project Cost Estimate details a breakdown of all of the estimated costs anticipated for this project.

4.3 Assessment Schedules

All properties that are within a project watershed boundary, or that are the site of construction works may be assessed costs associated with a drainage project.

Streamline Engineering has prepared Schedule C – Construction Assessments which shall govern the distribution of the costs for this project. It is the opinion of Streamline Engineering that the assessments provided are fair and equitable for all assessed properties.

The Engineer is authorized to assess project costs in accordance with Sections 22, 23, and 26 of the Drainage Act which are further described below.

Section 22 – Benefit

Benefit assessments are generally assessed to properties in the vicinity of where work is completed.

Benefit can be generally defined as advantages to any lands, roads, buildings or other structures resulting from the construction, improvement, repair or maintenance of a drainage works that will result in a higher market value, increased crop production, improved appearance, better control of surface or subsurface water, etc.

Section 23 – Outlet

Outlet assessments are distributed to all properties within a watershed area and are based on the volume and rate of flow of water from that property during a rainfall event. Based on the judgement of the Engineer, different land types are assessed at different outlet rates based on the amount of flow they are anticipated to contribute to the drainage system.

Section 26 – Special Assessment

Special assessments are utilized to directly assess increased costs that are required as a result of the existence of a roadway directly to the owner of that roadway.

Special assessments are calculated by first the determining the cost of a portion of the drain that is affected by the existence the road including all associated administration costs. Following this the cost of an “equivalent drain” is determined by estimating the cost of the portion of drain if the roadway did not exist. The difference between these two costs form the Special Assessment for the owner of the roadway.

For this project the following Special Assessments have been determined and all pertain to the Seventh Concession Road owned by the County of Brant:

Drain Name	Est. Construction Cost	Plus Est. Admin Cost	Less Equivalent Drain Cost	Est. Special Assessment
Main Drain	\$ 30,500	\$ 11,900	\$ 2,300	\$ 40,100
Branch A	\$ 23,000	\$ 11,700	\$ 1,700	\$ 33,000
Branch B	\$ 24,300	\$ 11,700	\$ 1,600	\$ 34,400
Branch E	\$ 12,100	\$ 5,700	\$ 0	\$ 17,800

The Special Assessments shall be finalized and assessed to the County of Brant based on the applicable actual construction costs.

4.4 Grant

Under the authorization of Section 85 of the Drainage Act, some properties may be eligible for an OMAFRA grant for up to $\frac{1}{3}$ of the property assessment. Grant eligibility is determined by the OMAFRA Agricultural Drainage Infrastructure Program (ADIP). A property is required to be used for agricultural purposes and have a Farm Property Tax Class rate in order to be eligible for the grant under this program. The County of Brant will be required to apply for this grant upon the completion of this project and if a property is eligible for to receive grant, it will be deducted from its assessment.

5 Future Considerations

5.1 Maintenance Costs

The County of Brant will be responsible for the maintenance of the proposed drain following its construction as authorized by Section 74 of the Drainage Act.

The County of Brant shall utilize Schedule D – Maintenance Assessments provided in this report to divide any maintenance costs using the same relative proportions until such time that the maintenance schedule is changed under the relevant process in the Drainage Act. Two schedules have been provided for the main drain, one for Branch A, and one for Branch B.

The County of Brant shall be responsible for all maintenance costs associated with the work on the right-of-way of the Seventh Concession Road.

5.2 Drain Abandonment

Section 19 of the Drainage Act provides the Engineer the ability to abandon any drain or part that is no longer useful or is being supplanted by a new drainage works. The following drains shall be considered abandoned and cease to have Municipal Drain Status following the construction of the proposed drain.

- The Terryberry Main Drain tile upstream of the catchbasin at station 0+845;
- The existing Branch A of the Terryberry drain upstream of the catchbasin at station A0+265;
- The entire tile length of Branch D of the Terryberry drain;
- The entire tile and channel length of Branch E of the Terryberry drain;
- The entire tile length of Branch F of the Terryberry drain;

5.3 Future Maintenance Specifics

All work proposed to be completed in this report shall be maintained as per the specifications and commentary in this report.

Work on channel in Kenny Creek Wetland Area

In the future, the Drainage Superintendent shall use non-intrusive methods (i.e. handwork when possible, avoid disturbance of trees and vegetation, using swamp mats if access with equipment is required, etc.), to the discretion of the Drainage Superintendent, to remove blockages and sediment in the channel and maintain the geometry of the channel within the Kenny Creek floodplain area from station 0+000 to -0+278. The channel shall be maintained to the specifics noted on the accompanying drawings.

Work in other Wetland Areas

While all existing tile and channel infrastructure shall be considered abandoned in the wetland areas adjacent to the Main Drain catchbasin located at station 0+845 and the Branch A catchbasin located

at station A0+502, the entirety of the wetland itself in both of these locations shall be considered to be part of the municipal drain system in the future (refer to the watershed plan to note the extents of these wetlands). The Drainage Superintendent shall have the authority to complete non-intrusive maintenance techniques methods (i.e. handwork when possible, avoid disturbance of trees and vegetation, using swamp mats if access with equipment is required, etc.) to their discretion to ensure that surface water can be conveyed by the station 0+845 and station A0+502 catchbasins at the elevations specified on the accompanying drawings to avoid flooding on the surrounding agricultural properties.

Future Maintenance of Main Drain South of Seventh Concession Road

No work on the Main drain is proposed between station 0+478 to 0+845 at this time. Despite this, a profile and catchbasin detail have been provided for future reference. The Drainage Superintendent shall maintain this portion of the drain as per the profile and detail provided in accordance to the tile installation special provision (SP6) and structure installation special provision (SP7) included in Appendix A.

Project Schedules

SCHEDULE A - ALLOWANCES

Main Drain						
Lot	Conc.	Property Owner	Roll No.	Right-of-Way (Sect. 29)	Damages (Sect. 30)	Totals
Pt. 12	7	Robert & Scott Bailey	4-420	\$ 500	\$ 200	\$ 700
Pt. 11 & Pt. 12	7	Crystal Benko & Mason Daviault	4-629	\$ 2,500	\$ -	\$ 2,500
Pt. 11 & Pt. 12	6	Danny, Janet & Justin Bailey	4-656	\$ 6,700	\$ 4,600	\$ 11,300
Pt. 11	7	Hog Farm Van Deelen Ltd	4-421	\$ 600	\$ -	\$ 600
SUBTOTAL - Main Drain				\$ 10,300	\$ 4,800	\$ 15,100
Branch A						
Lot	Conc.	Property Owner	Roll No.	Right-of-Way (Sect. 29)	Damages (Sect. 30)	Totals
Pt. 11 & Pt. 12	6	Danny, Janet & Justin Bailey	4-656	\$ 3,300	\$ 2,100	\$ 5,400
Pt. 11	7	Hog Farm Van Deelen Ltd	4-421	\$ 200	\$ 200	\$ 400
Pt. 11	6	Jerome & Wendy Davis	4-658	\$ 2,500	\$ 1,300	\$ 3,800
Pt. 10	6	Donald Martin	4-659	\$ 400	\$ -	\$ 400
SUBTOTAL - Branch A				\$ 6,400	\$ 3,600	\$ 10,000
Branch B						
Lot	Conc.	Property Owner	Roll No.	Right-of-Way (Sect. 29)	Damages (Sect. 30)	Totals
Pt. 11 & Pt. 12	6	Danny, Janet & Justin Bailey	4-656	\$ 800	\$ 500	\$ 1,300
Pt. 11	7	Hog Farm Van Deelen Ltd	4-421	\$ 200	\$ 200	\$ 400
SUBTOTAL - Branch B				\$ 1,000	\$ 700	\$ 1,700
TOTAL ALLOWANCES				\$ 17,700	\$ 9,100	\$ 26,800

SCHEDULE B - PROJECT COST ESTIMATE

GENERAL				
Item No.	SP No.*	Description	Approx. Quantity	Est. Cost
G1	1	Pre-Construction Meeting, Mobilization, De-Mobilization.	LS	\$5,300
G2	2	Supply 19mm (¾") clear crushed stone.	920 tonnes	\$26,700
G3	3	Tree clearing, grubbing, and brushing as specified.	LS	\$6,100
SUBTOTAL - GENERAL				\$38,100
Main Drain				
Item No.	SP No.*	Description	Approx. Quantity	Est. Cost
M1	4	Construct a temporary rock check dam (OPSD 219.211) c/w removal once construction area has stabilized (Sta. -0+038).	LS	\$1,300
M2	5	a) Construction of one stilling basin, including the supply and installation of rip-rap erosion protection, and channel construction as specified (Sta. -0+062 to 0+000).	LS	\$9,500
	9	b) Handseeding of exposed channel banks following channel excavation.	LS	\$700
M3	6	a) Supply 12m of 750mm dia. solid, plain end, HPDE pipe (320 kPa).	LS	\$3,800
		b) Supply one 750mm dia. solid, 45 degree HDPE elbow (320 kPa) with bell ends.	LS	\$600
		c) Install 12m of HDPE pipe and elbow at connection between HDPE pipes c/w the destruction of the existing Municipal drain (Sta. 0+000 to 0+012).	LS	\$2,100
M4	6	a) Supply 750mm dia. concrete tile (2000D) and required geotextile.	294 m	\$32,400
		b) Install concrete tile via excavator c/w the destruction of the existing Municipal drain (Sta. 0+012 to 0+306).	294 m	\$23,600
M5	7	a) Supply 900mm x 1,200mm concrete JB.	LS	\$1,900
		b) Install JB (Sta. 0+306).	LS	\$1,600
M6	6	a) Supply 525mm dia. concrete tile (2000D) and required geotextile.	154 m	\$8,200
		b) Supply one 525mm dia. solid, 45 degree HDPE elbow (320 kPa) with plain ends and required geotextile.	LS	\$500
		c) Install concrete tile via excavator c/w install of elbow as specified and the destruction of the existing Municipal drain (Sta. 0+306 to 0+460).	154 m	\$9,700
Work on the Seventh Concession Road				
M7	7	a) Supply 900mm x 1,200mm concrete CB.	LS	\$2,600
		b) Remove and dispose of existing DICB.	LS	\$500
		c) Install CB (Sta. 0+460).	LS	\$1,600
M8	8	a) Supply 525mm dia. solid, split coupler, HPDE pipe (320 kPa) and required couplers.	18 m	\$3,000

SCHEDULE B - PROJECT COST ESTIMATE

M8	8	b) Supply 450mm dia. solid, split coupler, HPDE pipe (320 kPa) and required couplers.	12 m	\$1,500
		c) Install 525mm dia. HDPE drain crossing and 450mm dia. HDPE culvert through Seventh Concession Road as per accompanying detail c/w removal of existing municipal pipe and road restoration as specified. (Sta. 0+460 to 0+478).	LS	\$12,400
M9	9	Handseeding of vegetated areas disturbed during crossing install.	LS	\$300
M10	7	a) Supply 900mm x 1,200mm concrete DICB.	LS	\$2,600
		b) Remove and dispose of existing DICB.	LS	\$500
		c) Install DICB.	LS	\$1,600
		d) Supply & install approx. 6m of 375mm dia. solid, HDPE pipe (320 kPa) and one 375mm dia., solid 45 degree HDPE elbow (320 kPa) with bell ends for connection of ex. municipal drain to CB (Sta. 0+478).	LS	\$800
SUBTOTAL - Main Drain				\$123,300
Branch A				
Item No.	SP No.*	Description	Approx. Quantity	Est. Cost
A1	6	a) Supply 450mm dia. concrete tile (2000D) and required geotextile.	265 m	\$11,100
		b) Install concrete tile via excavator c/w the destruction of the existing Municipal drain (Sta. A0+000 to A0+265).	265 m	\$15,000
A2	7	a) Supply 900mm x 1,200mm concrete CB.	LS	\$2,600
		b) Install CB (Sta. A0+265).	LS	\$1,600
		c) Supply & install approx. 3m of 300mmØ solid, plastic ag. tubing for connection of ex. Branch A drain to CB (Sta. 0+478).	LS	\$300
A3	6	a) Supply 400mm dia. concrete tile (2000D) and required geotextile.	159 m	\$5,800
		b) Supply one 400mm dia. solid, plain end, 45 degree HDPE elbow (320 kPa) and required geotextile.	LS	\$500
		c) Install concrete tile via excavator c/w install of elbow as specified (Sta. A0+265 to A0+424).	159 m	\$8,300
A4	6	a) Supply 375mm dia. solid, gasketed, bell & spigoted, HPDE pipe (320 kPa).	78 m	\$7,000
		b) Supply one 375mm dia. solid, 22.5 degree HDPE elbow (320 kPa) with bell ends.	LS	\$400
		c) Install HDPE pipe via excavator c/w install of elbow as specified (Sta. A0+424 to A0+502).	78 m	\$2,900
Work on the Seventh Concession Road				
A5	7	a) Supply 600mm x 600mm concrete CB.	LS	\$2,100
		b) Remove and dispose of existing DICB.	LS	\$500
		c) Install CB (Sta. A 0+502).	LS	\$1,100

SCHEDULE B - PROJECT COST ESTIMATE

A6	8	a) Supply 300mm dia. solid, split coupler, HPDE pipe (320 kPa) and required couplers.	18 m	\$1,000
		b) Supply 450mm dia. solid, split coupler, HPDE pipe (320 kPa) and required couplers.	15 m	\$1,900
		c) Install 300mm dia. HDPE drain crossing and 450mm dia. HDPE culvert through Seventh Concession Road as per accompanying detail c/w removal of existing municipal pipe and road restoration as specified. (Sta. A0+502 to A0+520).	LS	\$9,900
A7	9	Handseeding of vegetated areas disturbed during crossing install.	LS	\$300
A8	7	a) Supply 600mm x 600mm concrete DICB.	LS	\$2,100
		b) Remove and dispose of existing DICB.	LS	\$500
		c) Install DICB (Sta. A0+520).	LS	\$1,100
SUBTOTAL - Branch A				\$76,000

Branch B

Item No.	SP No.*	Description	Approx. Quantity	Est. Cost
B1	6	a) Supply 300mm dia. solid, split coupler HPDE pipe (320 kPa) and required couplers.	63 m	\$3,600
		b) Install HDPE pipe via excavator c/w the destruction of the existing Municipal drain (Sta. B0+000 to B0+063).	63 m	\$2,300
Work on the Seventh Concession Road				
B2	7	a) Supply 600mm x 600mm concrete CB.	LS	\$2,100
		b) Remove and dispose of existing DICB.	LS	\$500
		c) Install CB (Sta. B0+063).	LS	\$1,100
B3	8	a) Supply 300mm dia. solid, split coupler, HPDE pipe (320 kPa) and required couplers.	18 m	\$1,000
		b) Supply 450mm dia. solid, split coupler, HPDE pipe (320 kPa) and required couplers.	LS	\$1,900
		c) Install 300mm dia. HDPE drain crossing and 450mm dia. HDPE culvert through Seventh Concession Road as per accompanying detail c/w removal of existing municipal pipe and road restoration as specified. (Sta. B0+063 to B0+081).	LS	\$9,900
B4	9	Handseeding of vegetated areas disturbed during crossing install.	LS	\$300
B5	7	a) Supply 600mm x 600mm concrete CB.	LS	\$2,100
		b) Remove and dispose of existing DICB.	LS	\$500
		c) Install CB.	LS	\$1,100
		d) Supply & install approx. 3m of 200mm dia. solid, plastic ag. tubing for connection of ex. private drain to CB (Sta. B0+081).	LS	\$400
SUBTOTAL - Branch B				\$26,800

SCHEDULE B - PROJECT COST ESTIMATE

Branch E				
Item No.	SP No.*	Description	Approx. Quantity	Est. Cost
Work on the Seventh Concession Road				
E1	7	Remove and dispose of existing DICB.	LS	\$500
E2	8	a) Supply 450mmØ solid, split coupler, HPDE pipe (320 kPa) and required couplers. b) Install 450mmØ HDPE culvert through Seventh Concession Road as per accompanying detail c/w removal of existing municipal pipe and road restoration as specified.	15 m LS	\$1,900 \$7,600
E3	9	Handseeding of vegetated areas disturbed during crossing install.	LS	\$300
E4	7	Remove and dispose of existing DICB.	LS	\$500
SUBTOTAL - Branch E				\$10,800
Provisional Costs				
These costs are included to account for construction activities that may or may not be required at the time of construction.				
Item No.	SP No.*	Description	Approx. Quantity	Est. Cost
P1	10	Tile connections into the proposed drain with core drilled hole and coupler. a) 100mm dia. connection b) 150mm dia. connection	5 ea. 5 ea.	\$1,100 \$1,600
P2	11	Supply and install Granular 'B' material	100 tonne	\$2,600
P3	12	Increased cost to install drain on wrapped 19mm (¾") clear stone bedding in areas of soil instability as per the Drain Installation on Wrapped Stone Bedding detail, not including the supply of clear stone. a) 300mm dia. to 450mm dia. pipe b) 525mm dia. to 750mm dia. pipe	100 m 100 m	\$7,400 \$8,400
SUBTOTAL - Provisional Costs				\$21,100
TOTAL ESTIMATED CONSTRUCTION COST				\$296,100

*SP No. refers to the Special Provisions - Project Specific Construction Specification associated with the item

SCHEDULE B - PROJECT COST ESTIMATE

SUMMARY OF COSTS	
Construction	
Total estimated cost of construction	\$296,100
Allowances	
Allowances to property owners	\$26,800
Administration	
Public meetings, survey, design and drafting, preparation of cost estimates and assessments, drainage report preparation, presentation at the Consideration of the drainage report	\$59,000
Tendering, contract administration and construction review	\$26,500
Miscellaneous project expenses (i.e. printing, permitting fees, mileage, estimated interest charges, net HST, etc.)	\$27,600
TOTAL ESTIMATED PROJECT COST	\$436,000

The above costs are estimates only. The final costs of construction, and administration cannot be determined until the project is completed.

These estimates do not include costs to defend the Drainage Report should appeals be filed with the Court of Revision, Drainage Tribunal, and/or Drainage Referee.

SCHEDULE C - CONSTRUCTION ASSESSMENTS

Terryberry Municipal Drain Improvement Summary					
Private Lands (The County of Brant)					
Lot	Conc.	Property Owner	Roll No.	Affected Area (acres)	Total Assessment
Pt. 12	7	Robert & Scott Bailey	4-420	22.3	\$ 28,200
Pt. 11 & Pt. 12	7	Crystal Benko & Mason Daviault	4-629	30.9	\$ 26,600
Pt. 11 & Pt. 12	6	Danny, Janet & Justin Bailey	4-656	41.8	\$ 90,200
Pt. 11	7	Jeffery & Mindy Gulas	4-423	4.8	\$ 5,000
Pt. 11	7	Hog Farm Van Deelen Ltd	4-421	36.0	\$ 63,900
Pt. 11	6	Jerome & Wendy Davis	4-658	22.8	\$ 45,300
Pt. 10	6	Donald Martin	4-659	9.4	\$ 15,600
SUBTOTAL - Private Lands (The County of Brant)				168.0	\$ 274,800
Roads					
Road Name		Property Owner	Affected Area (acres)		Total Assessment
Seventh Concession Road		* County of Brant	4.3		\$ 35,900
SUBTOTAL - Roads				4.3	\$ 35,900
Special Assessments (Sect. 26)					
Special Assessments against the County of Brant for work on Seventh Concession Road					\$ 125,300
SUBTOTAL - Special Assessment					\$ 125,300
Total Affected Area (acres)				172.3	
TOTAL COST - TERRYBERRY MUNICIPAL DRAIN IMPROVEMENT					\$436,000

For Information Purposes Only		
Total Allowances	OMAFRA 1/3 Grant	Est. Net Assessment
\$ 700	\$ 9,400	\$ 18,100
\$ 2,500	\$ 8,867	\$ 15,233
\$ 18,000	\$ 30,067	\$ 42,133
\$ -	\$ 1,667	\$ 3,333
\$ 1,400	\$ 21,300	\$ 41,200
\$ 3,800	\$ 15,100	\$ 26,400
\$ 400	\$ 5,200	\$ 10,000
\$ 26,800	\$ 91,600	\$ 156,400

Notes:

Properties are presumed to have agricultural tax class, and thus be eligible for a 1/3 OMAFRA grant, with the exception of properties denoted with a "**". Property owners shall note it is their individual responsibility to confirm the tax class of each of their properties and verify grant eligibility under the most current agricultural drain infrastructure (ADIP) policies.

SCHEDULE C - CONSTRUCTION ASSESSMENTS

Main Drain							
Private Lands (The County of Brant)							
Lot	Conc.	Property Owner	Roll No.	Affected Area (acres)	Benefit (Sect. 22)	Outlet (Sect. 23)	Total Assessment
Pt. 12	7	Robert & Scott Bailey	4-420	22.3	\$ 5,900	\$ 22,300	\$ 28,200
Pt. 11 & Pt. 12	7	Crystal Benko & Mason Daviault	4-629	30.9	\$ -	\$ 26,600	\$ 26,600
Pt. 11 & Pt. 12	6	Danny, Janet & Justin Bailey	4-656	41.8	\$ 41,000	\$ 24,300	\$ 65,300
Pt. 11	7	Jeffery & Mindy Gulas	4-423	4.8	\$ -	\$ 5,000	\$ 5,000
Pt. 11	7	Hog Farm Van Deelen Ltd	4-421	36.0	\$ -	\$ 28,200	\$ 28,200
Pt. 11	6	Jerome & Wendy Davis	4-658	22.8	\$ -	\$ 13,500	\$ 13,500
Pt. 10	6	Donald Martin	4-659	9.4	\$ -	\$ 6,100	\$ 6,100
SUBTOTAL - Private Lands (The County of Brant)				168.0	\$ 46,900	\$ 126,000	\$ 172,900
Roads							
Road Name		Property Owner		Affected Area (acres)	Benefit (Sect. 22)	Outlet (Sect. 23)	Total Assessment
Seventh Concession Road		* County of Brant		4.3	\$ 5,900	\$ 10,300	\$ 16,200
SUBTOTAL - Roads				4.3	\$ 5,900	\$ 10,300	\$ 16,200
Special Assessments (Sect. 26)							
Special Assessment against the County of Brant for work on Seventh Concession Road							\$ 40,100
SUBTOTAL - Special Assessment							\$ 40,100
Total Affected Area (acres)				172.3			
TOTAL COST - MAIN DRAIN							\$229,200

For Information Purposes Only		
Total Allowances	OMAFRA 1/3 Grant	Est. Net Assessment
\$ 700	\$ 9,400	\$ 18,100
\$ 2,500	\$ 8,867	\$ 15,233
\$ 11,300	\$ 21,767	\$ 32,233
\$ -	\$ 1,667	\$ 3,333
\$ 600	\$ 9,400	\$ 18,200
\$ -	\$ 4,500	\$ 9,000
\$ -	\$ 2,033	\$ 4,067
\$ 15,100	\$ 57,633	\$ 100,167

Notes:

Properties are presumed to have agricultural tax class, and thus be eligible for a 1/3 OMAFRA grant, with the exception of properties denoted with a "*". Property owners shall note it is their individual responsibility to confirm the tax class of each of their properties and verify grant eligibility under the most current agricultural drain infrastructure (ADIP) policies.

SCHEDULE C - CONSTRUCTION ASSESSMENTS

Branch A							
Private Lands (The County of Brant)							
Lot	Conc.	Property Owner	Roll No.	Affected Area (acres)	Benefit (Sect. 22)	Outlet (Sect. 23)	Total Assessment
Pt. 11 & Pt. 12	6	Danny, Janet & Justin Bailey	4-656	10.2	\$ 20,200	\$ 3,900	\$ 24,100
Pt. 11	7	Hog Farm Van Deelen Ltd	4-421	25.4	\$ 8,300	\$ 19,600	\$ 27,900
Pt. 11	6	Jerome & Wendy Davis	4-658	22.8	\$ 17,900	\$ 13,900	\$ 31,800
Pt. 10	6	Donald Martin	4-659	9.4	\$ -	\$ 9,500	\$ 9,500
SUBTOTAL - Private Lands (The County of Brant)				67.8	\$ 46,400	\$ 46,900	\$ 93,300
Roads							
Road Name		Property Owner		Affected Area (acres)	Benefit (Sect. 22)	Outlet (Sect. 23)	Total Assessment
Seventh Concession Road		* County of Brant		2.8	\$ 8,300	\$ 6,900	\$ 15,200
SUBTOTAL - Roads				2.8	\$ 8,300	\$ 6,900	\$ 15,200
Special Assessments (Sect. 26)							
Special Assessment against the County of Brant for work on Seventh Concession Road							\$ 33,000
SUBTOTAL - Special Assessment							\$ 33,000
Total Affected Area (acres)				70.6			
TOTAL COST - BRANCH A							\$141,500

For Information Purposes Only		
Total Allowances	OMAFRA 1/3 Grant	Est. Net Assessment
\$ 5,400	\$ 8,033	\$ 10,667
\$ 400	\$ 9,300	\$ 18,200
\$ 3,800	\$ 10,600	\$ 17,400
\$ 400	\$ 3,167	\$ 5,933
\$ 10,000	\$ 31,100	\$ 52,200

Notes:

Properties are presumed to have agricultural tax class, and thus be eligible for a 1/3 OMAFRA grant, with the exception of properties denoted with a "***". Property owners shall note it is their individual responsibility to confirm the tax class of each of their properties and verify grant eligibility under the most current agricultural drain infrastructure (ADIP) policies.

SCHEDULE C - CONSTRUCTION ASSESSMENTS

Branch B							
Private Lands (The County of Brant)							
Lot	Conc.	Property Owner	Roll No.	Affected Area (acres)	Benefit (Sect. 22)	Outlet (Sect. 23)	Total Assessment
Pt. 11 & Pt. 12	6	Danny, Janet & Justin Bailey	4-656	0.0	\$ 800	\$ -	\$ 800
Pt. 11	7	Hog Farm Van Deelen Ltd	4-421	13.3	\$ 3,400	\$ 4,400	\$ 7,800
SUBTOTAL - Private Lands (The County of Brant)				13.3	\$ 4,200	\$ 4,400	\$ 8,600
Roads							
Road Name		Property Owner		Affected Area (acres)	Benefit (Sect. 22)	Outlet (Sect. 23)	Total Assessment
Seventh Concession Road		* County of Brant		1.2	\$ 3,500	\$ 1,000	\$ 4,500
SUBTOTAL - Roads				1.2	\$ 3,500	\$ 1,000	\$ 4,500
Special Assessments (Sect. 26)							
Special Assessment against the County of Brant for work on Seventh Concession Road							\$ 34,400
SUBTOTAL - Special Assessment							\$ 34,400
Total Affected Area (acres)				14.5			
TOTAL COST - BRANCH B							\$47,500

For Information Purposes Only		
Total Allowances	OMAFRA 1/3 Grant	Est. Net Assessment
\$ 1,300	\$ 267	\$ (767)
\$ 400	\$ 2,600	\$ 4,800
\$ 1,700	\$ 2,867	\$ 4,033

Notes:

Properties are presumed to have agricultural tax class, and thus be eligible for a 1/3 OMAFRA grant, with the exception of properties denoted with a "***". Property owners shall note it is their individual responsibility to confirm the tax class of each of their properties and verify grant eligibility under the most current agricultural drain infrastructure (ADIP) policies.

Branch E	
Special Assessments (Sect. 26)	
Special Assessment against the County of Brant for work on Seventh Concession Road	\$ 17,800
SUBTOTAL - Special Assessment	\$ 17,800
TOTAL COST - BRANCH E	\$17,800

SCHEDULE D - MAINTENANCE ASSESSMENTS

Main Drain Downstream of Branch A				
Private Lands (The County of Brant)				
Lot	Conc.	Property Owner	Roll No.	Portion of Maint. Cost
Pt. 12	7	Robert & Scott Bailey	4-420	12.2%
Pt. 11 & Pt. 12	7	Crystal Benko & Mason Daviault	4-629	14.5%
Pt. 11 & Pt. 12	6	Danny, Janet & Justin Bailey	4-656	25.1%
Pt. 11	7	Jeffery & Mindy Gulas	4-423	2.7%
Pt. 11	7	Hog Farm Van Deelen Ltd	4-421	20.9%
Pt. 11	6	Jerome & Wendy Davis	4-658	11.6%
Pt. 10	6	Donald Martin	4-659	5.2%
Roads				
Road Name		Property Owner	Portion of Maint. Cost	
Seventh Concession Road		* County of Brant	7.8%	
TOTALS				100.0%

Main Drain Upstream of Branch A				
Private Lands (The County of Brant)				
Lot	Conc.	Property Owner	Roll No.	Portion of Maint. Cost
Pt. 12	7	Robert & Scott Bailey	4-420	29.5%
Pt. 11 & Pt. 12	7	Crystal Benko & Mason Daviault	4-629	35.1%
Pt. 11 & Pt. 12	6	Danny, Janet & Justin Bailey	4-656	8.7%
Pt. 11	7	Jeffery & Mindy Gulas	4-423	6.5%
Pt. 11	7	Hog Farm Van Deelen Ltd	4-421	13.6%
Roads				
Road Name		Property Owner	Portion of Maint. Cost	
Seventh Concession Road		* County of Brant	6.6%	
TOTALS				100.0%

Notes:

Properties are presumed to have agricultural tax class, and thus be eligible for a 1/3 OMAFRA grant, with the exception of properties denoted with a "*". Property owners shall note it is their individual responsibility to confirm the tax class of each of their properties and verify grant eligibility under the most current agricultural drain infrastructure (ADIP) policies.

SCHEDULE D - MAINTENANCE ASSESSMENTS

Branch A				
Private Lands (The County of Brant)				
Lot	Conc.	Property Owner	Roll No.	Portion of Maint. Cost
Pt. 11 & Pt. 12	6	Danny, Janet & Justin Bailey	4-656	14.2%
Pt. 11	7	Hog Farm Van Deelen Ltd	4-421	35.2%
Pt. 11	6	Jerome & Wendy Davis	4-658	26.8%
Pt. 10	6	Donald Martin	4-659	12.1%
Roads				
Road Name		Property Owner	Portion of Maint. Cost	
Seventh Concession Road		* County of Brant	11.7%	
TOTALS				100.0%

Branch B				
Private Lands (The County of Brant)				
Lot	Conc.	Property Owner	Roll No.	Portion of Maint. Cost
Pt. 11	7	Hog Farm Van Deelen Ltd	4-421	78.7%
Roads				
Road Name		Property Owner	Portion of Maint. Cost	
Seventh Concession Road		* County of Brant	21.3%	
TOTALS				100.0%

Notes:

Properties are presumed to have agricultural tax class, and thus be eligible for a 1/3 OMAFRA grant, with the exception of properties denoted with a "*". Property owners shall note it is their individual responsibility to confirm the tax class of each of their properties and verify grant eligibility under the most current agricultural drain infrastructure (ADIP) policies.

Appendix A
Construction Specifications

Table of Contents

1	Special Provisions.....	1
1.1	Working Space and Access Routes.....	1
1.2	Utilities.....	1
1.3	Anticipated Soil Conditions.....	2
1.4	Agency Project Requirements.....	2
1.5	Project Specific Construction Specifications.....	2
SP1	Pre-Construction Meeting, Mobilization, and De-Mobilization.....	2
SP2	Supply 19mm (¾ inch) Diameter Clearstone.....	3
SP3	Clearing, Grubbing, and Brushing.....	3
SP4	Temporary Rock Flow Check Dam.....	4
SP5	Stilling Basin and Channel Construction.....	4
SP6	Tile Installation.....	5
SP7	Structure Installation.....	9
SP8	Seventh Concession Road Open Cut Crossings.....	10
SP9	Seeding.....	12
SP10	Tile Connections.....	12
SP11	Supply and Install Granular 'B'.....	12
SP12	Special Installation Technique.....	12
2	General Requirements.....	14
2.1	Periodic and Final Construction Review.....	14
2.2	Existing Conditions.....	14
2.3	Benchmarks and Temporary Construction Markers.....	14
2.4	Material Specifications.....	14
2.5	Iron Bars.....	15
2.6	Pollution.....	15
2.7	Fences.....	15
2.8	Livestock and Standing Crops.....	16
2.9	Material Disposal.....	16
2.10	Removal of Large Stones and Rock.....	16
2.11	Damage by Vehicles and Other Equipment.....	16
2.12	Equipment and Material Staging.....	16
2.13	Deficient Items.....	16
2.14	Construction Document Errors.....	17
2.15	Alterations to Work.....	17
2.16	Liquidated Damages.....	17
2.17	Sub-Contractors.....	18
2.18	Payment.....	18
2.19	Project Completion/Substantial Performance.....	18

APPENDIX A – CONSTRUCTION SPECIFICATIONS

2.20 Statutory Holdback 18

2.21 Warranty Holdback..... 18

2.22 Tests 19

2.23 Species at Risk 19

2.24 Weather 19

2.25 Dewatering..... 19

2.26 Erosion and Sediment Control 20

2.27 Seeding 20

3 General Specifications for Open Drains..... 21

3.1 Profile..... 21

3.2 Tile Outlets 21

3.3 Crossing of Open Drains..... 21

4 General Specifications for Tile Drains..... 22

4.1 Alignment..... 22

4.2 Profile..... 22

4.3 Trench Crossings 22

1 Special Provisions

Special Provisions are directions specific to this project. A project specific specification is included in the Special Provisions for each line item bid for the project. Should a discrepancy be noted between the Special Provisions and General Conditions/Specifications, the Special Provisions shall take precedence.

1.1 Working Space and Access Routes

The Contractor shall be entitled to undertake work and stage construction equipment/materials in the following working areas:

- A 10m width to the west side of the new channel portion of the municipal drain
- For future maintenance, a 10m width to the east side of the channel portion of the municipal drain
- A 20m width centered on the proposed tile drain
- A 6m width centered on the existing tile drain where tile destruction only is required
- A 20m x 20m construction staging area as required on the Danny, Janet, & Justin Bailey property (Roll No. 4-656)

The Contractor shall be entitled to utilize the following access routes, which shall be a maximum 6m in width:

- Access Route #1 – From Highway 53 to the farm access laneway on Lot 11, Concession 6 along the edge of the agricultural lands to the proposed tile alignment.
- Access Route #2 – From the north side of the Seventh Concession Road ROW and the west side of the wetland on the Jerome & Wendy Davis (Roll No. 4-658) property to the farm access located approximately 80m west of the Branch A drain crossing of Seventh Concession Road.
- The Contractor shall access the drain from the Seventh Concession Road ROW directly adjacent to any proposed drain crossing. The Contractor shall be responsible to complete any work necessary to provide temporary access from the Seventh Concession Road ROW as well as restoration after the completion of construction.

The Contractor shall obtain approval from the Contract Administrator and relevant property owner(s) prior to exceeding the noted working spaces, or if they wish to use an alternative access route. The Contractor shall be responsible for any damages to lands, crops, etc. outside of the specified working areas or access routes.

1.2 Utilities

A utilities investigation was undertaken during the design stage to determine possible conflicts prior to the time of construction. The following utilities were noted in the area of the proposed drain:

- The work area was noted to be clear of buried hydro lines
- One overhead hydro line located on the northern half of Seventh Concession Road

- One overhead hydro line crossing Seventh Concession Road approx. 3m east of Branch E
- One telephone line located on the southern half of Seventh Concession Road

All public and private utilities shall be located by the Contractor prior to the construction of the proposed drain. If required by the specific utility, the Contractor shall be responsible to coordinate for a representative of the utility to be on-site during the relevant construction works.

1.3 Anticipated Soil Conditions

No soils investigation was completed for this project, however soils are anticipated to be generally sandy. The Contractor shall note the increased likelihood of water sand (i.e. quicksand) conditions for this project and schedule their construction activities accordingly.

1.4 Agency Project Requirements

The Contractor shall ensure that all relevant permits have been obtained prior to the commencement of any regulated construction activities and if required, ensure that they have a printed copy of the permit(s) available on-site.

Grand River Conservation Authority (GRCA)

The Contractor shall establish erosion and sediment control measures (i.e. rock check dam) at the onset of the project and remove any accumulated sediment as required to ensure continued effectiveness throughout construction.

The Department of Fisheries and Oceans Canada (DFO)

No works in an existing channel are proposed as part of this report and as a result, there are no DFO requirements for this project.

The Ministry of Environment, Conservation and Parks (MECP)

There is no indication of any adverse impacts to Species at Risk because of the proposed works.

1.5 Project Specific Construction Specifications

SP1 Pre-Construction Meeting, Mobilization, and De-Mobilization

The Contractor shall not complete any construction activities prior to an executed Contract being completed, as well as confirmation of their anticipated construction start date with the Contract Administrator.

The Contractor shall be responsible to notify all property owners, the Drainage Superintendent and Contract Administrator and conduct a pre-construction meeting prior to the commencement of any construction activities. A minimum 48 hours' notice shall be provided by the Contractor.

Furthermore, this item covers the Contractor's costs associated with facilitation and attendance at the pre-construction meeting, the transportation and/or accommodation (meals and lodging) of labour, equipment, offices, conveniences, and other items not required to form part of the permanent works and not covered by other items in the Schedule of Unit Prices. This line item shall only apply to the first/ primary mobilization/demobilization required to fulfill the Contract. Additional mobilization costs will not be paid if the Contractor chooses to leave the site on their own accord following the initial mobilization. However, if at the discretion of the Contract Administrator a situation warrants the Contractor to demobilize from site to complete the remainder of the work at a later date, the costs associated with this may be negotiated with the Contract Administrator and paid as an extra item.

Payment at the Lump Sum price set out in the schedule of unit prices for the pre-construction meeting, mobilization and demobilization will be made as follows:

- 25% payable following the pre-construction meeting.
- 50% payable following the first mobilization.
- 25% payable on the Substantial Performance of the Contract.

SP2 Supply 19mm (¾ inch) Diameter Clearstone

For the unit price bid per tonne, the Contractor shall supply 19mm (¾ inch) dia. clear crushed stone. This unit price shall be used as payment for **all** 19mm clear crushed stone installed for this project.

The Contractor shall provide tickets and/or adequate supporting documentation to the Contract Administrator to support the quantity of clearstone proposed to be paid.

SP3 Clearing, Grubbing, and Brushing

Clearing means the cutting of all standing trees, brushing, and other vegetation to a maximum height of 300mm above the original ground level.

All trees greater than 150mm in diameter shall be felled, delimbed, cut into lengths no larger than 6m, and neatly stacked in piles to the satisfaction of the Contract Administrator.

Grubbing means the removal of all stumps, roots, embedded logs, debris, and secondary growth. The Contractor shall remove and dispose of all grubbed material off-site. Burying of grubbed material shall not be permitted.

Brushing means the removal of trees, limbs, and brush less than 150mm in diameter by the using one of the following methods:

- Chipped in place by an excavator equipped with a hydraulic brushing attachment.
- Chipped using a woodchipper and piled or spread within the ROW
- Piled and burned in accordance with the County of Brant's burning regulations and by-law(s)

The method preferred by the Contractor shall be discussed at the pre-construction meeting and shall be completed to the satisfaction of the Contract Administrator.

Any trees required to be removed for this project are specified in the table below:

Station Range	Description of Work
Main Drain	
-0+062 to 0+012	<ul style="list-style-type: none"> • Clearing and brushing of trees within the working space. There are expected to be approximately ten trees ranging in diameter from 0.15m to 1.2m in diameter within the working space. • Grubbing as required to facilitate the tile installation and channel excavation.
Branch A	
A0+170	<ul style="list-style-type: none"> • Clear and grub one large tree (approx. 0.6m in diameter) within the working space. • Tree to be piled with others along the property line at station A0+265.
A0+263 to A0+272	<ul style="list-style-type: none"> • Clear and brush trees within the working space. There is expected to be approximately five trees greater than 0.3m in diameter within the working space that are required to be removed. There is expected to be approximately two trees greater than 0.3m in diameter near the edge of the working space that may be required to be removed. • Grubbing as required to facilitate construction. • De-limbed trees greater than 150mm in diameter to be piled along the property line near station A0+265.
Branch B	
B0+045 to B0+063	<ul style="list-style-type: none"> • Clear and grub one large tree (approximately 0.8m in diameter) within the working space. • Tree to be piled with others along the property line at station A0+265.

SP4 Temporary Rock Flow Check Dam

The Contractor shall install a temporary rock flow check dam as per OPSD 219.211 at approximately station -0+038, prior to commencement of any work on the remainder of the proposed drain. After the completion of the work and when so instructed by the Contract Administrator, the rock flow check dam shall be removed. The excess stone may be incorporated into the surrounding channel features.

SP5 Stilling Basin and Channel Construction

A permanent stilling basin shall be installed immediately downstream of the outlet pipe as per the accompanying details to the satisfaction of the Contract Administrator.

The basin shall be lined with approximately 15m² of rip-rap (450mm thickness of 150 to 300mm dia.) in the base of the stilling basin and spillway from station -0+010 to station 0+000.

APPENDIX A – CONSTRUCTION SPECIFICATIONS

Additionally, approximately 35m² of rip-rap (450mm thickness of 150 to 300mm diameter quarry stone with geotextile underlay) shall be installed on the side banks from station -0+010 to station 0+000 and on the same bank as the outlet pipe, as erosion protection to a minimum elevation of 355.48m.

The Contractor shall consider the below information in their bid for the proposed channel works.

Station Range	Approx. Volume of Exc.	Description of Work
-0+062 to 0+000	70m ³	<ul style="list-style-type: none"> Excavated material shall be placed on the west side of the drain and a clear buffer of at least 1m shall be maintained between the top edge of the open drain and all excavated material. No excavated material be left in any low runs, depressions, or low areas which would cause water to pond behind the spoil bank. The excavated spoil shall be levelled to a maximum depth of 200mm. The dimensions of the channel shall be trapezoidal with a 1.0m bottom width, side slopes no steeper than 2H:1V, and to the elevations noted on the accompanying drawings. The course of the channel shall be directly from the outlet of the Municipal tile to the existing channel, as directed by the Contract Administrator.

SP6 Tile Installation

All concrete tile shall be 2000D strength. All HDPE pipe shall be solid dual-wall (i.e. smooth inner wall) pipe with a minimum 320 kPa stiffness at 5% deflection.

Topsoil Stripping

Prior to the installation of the new tile, or destruction of the existing tile, in all locations the Contractor shall strip the topsoil from the area of the proposed tile trench as per the table below. The topsoil shall be stockpiled separately from the subsoil material.

Tile Diameter	Minimum Topsoil Stripping Width
<450mm	4m
450mm – 750mm	6m

Where the tile installation exceeds the maximum digging depth of the Contractor's excavator, they shall lower the surface grade in order that the excavator may excavate at the correct depth. The Contractor shall complete any additional stripping required to facilitate the work. The Contractor shall consider the additional stripping and excavating required in their bid of the associated line item.

Trenching

All trenching shall be carried out with an excavator and the pipe shall be installed with 19mm clearstone bedding and backfill as per the accompanying details. The minimum trench shall be equal to the outside diameter of the pipe plus 100mm on each side of the pipe. The maximum trench width shall be equal to the outside diameter of the pipe plus 300mm on each side of the pipe.

Concrete Tile Installation

The concrete tiles shall be laid carefully so that successive tiles align both horizontally and vertically as firmly as possible and at a regular grade and alignment in accordance with the drawings. The maximum acceptable gap between any tiles shall be 10mm. Any ground/debris along the edges, faces, or inside of the tile shall be scraped off by the Contractor prior to the tile being laid. If requested by the Contract Administrator, the Contractor shall use a concrete saw to cut the edges of any concrete tile to bevel the tile and minimize the gap between the butt joints at a turn in the proposed drain.

The Contractor shall wrap all concrete tile joints with RM-150 (4 oz.) non-woven geotextile or approved equivalent centered on the tile joints with the following minimum widths.

- 300mm wide for tiles sizes smaller than 450mm in diameter
- 400mm wide for tiles sizes 450mm in diameter or larger

High Density Polyethylene Pipe Installation

All HDPE pipe shall be laid carefully so that the successive tiles align both horizontally and vertically as firmly as possible and at a regular grade and alignment in accordance with the drawings. The joints of the HDPE pipe shall be secured with a prefabricated coupler, or with the spigoted end of the pipe inserted into a gasketed bell end of the successive pipe to the satisfaction of the Contract Administrator.

Backfilling

Once sufficient time has been given for the Contract Administrator to verify the elevation of the tile, backfilling of the trench may commence. The tile installation trench shall be backfilled by the Contractor at the end of each working day. Clean native material free of stones greater than 150mm in diameter and organic material shall be used within 300mm of the proposed tile. In cases, where in the opinion of the Contract Administrator the backfill material is too stony to be used as backfill around the tile, the Contractor shall use 19mm clear stone as backfill up to 150mm overtop of the tile. The Contractor shall take care to ensure that the area between the tile and the trench wall is backfilled as to avoid any voids between the tile and the trench wall. The remainder of the trench may be backfilled with the remaining native material.

Topsoil Restoration

APPENDIX A – CONSTRUCTION SPECIFICATIONS

Following backfilling with the native material, the topsoil shall be replaced to the satisfaction of the Contract Administrator. The trench shall be mounded to allow for the settlement of the backfill material to ensure that no depression remains after settling has occurred, and conversely that the trench can be easily cultivated with ordinary farm equipment without causing undue hardship to the farm machinery and farm personnel.

Under no circumstances shall frozen topsoil be levelled or placed over top of the drain. If the Contractor elects to install the drain during winter months, the Contractor shall return to the site and level the topsoil when conditions are appropriate. No additional mobilization charges shall be made for returning the site to complete the levelling of topsoil.

Tile Installation Specifics

The proposed drain shall be bid and installed considering information highlighted in the table below:

Station Range	Comments
Main Drain	
0+000 to 0+012	<ul style="list-style-type: none"> • The existing Municipal drain is offset from the proposed alignment and shall be destroyed in place in its entirety on agricultural lands along this length. • Tree removals are required through this length. Contractor to ensure organic material such as tree roots are absent from the trench backfill. • Two, 6m lengths (12m total) of 750mm dia. HDPE pipe shall be supplied, as well as one 750mm dia. solid, bell and spigoted, 45° HDPE elbow (320 kPa). The elbow shall be installed at the joint between the two lengths of HDPE pipe to the satisfaction of Contract Administrator. • The HDPE pipe shall be butt jointed to the concrete tile at 0+012 and double wrapped with geo-textile.
0+012 to 0+460	<ul style="list-style-type: none"> • The proposed Municipal drain shall not follow the natural low run, but be installed along the alignment shown in the accompanying drawings. It shall be installed in as straight a line as possible to the satisfaction of the Contract Administrator. • For backfilling in this section, areas with less than 0.9m of cover shall be locally regraded by the Contractor to establish a minimum cover of 0.9m. • A 45°, 525mmØ HDPE elbow to be installed at approximately station 0+459. There shall be only one length of concrete tile downstream of the CB at station 0+460 before the elbow is butt-jointed to the HDPE elbow. Both elbow joints shall be double-wrapped with geotextile. • The existing Municipal drain shall be destroyed in place in its entirety along this length and it should be noted by the Contractor

APPENDIX A – CONSTRUCTION SPECIFICATIONS

	<p>that this alignment is notably different that that of the proposed tile alignment.</p> <ul style="list-style-type: none"> Following the destruction of the existing tile, the Contractor shall restore any existing tile blowout areas to allow these areas to be farmed following construction. Of note in this area are blowouts at station 0+225 and station 0+375.
Branch A	
A0+000 to A0+265	<ul style="list-style-type: none"> The existing Municipal drain shall be destroyed in place in its entirety along this length. Tree clearing and grubbing required at station A0+170. Following the destruction of the existing tile, the Contractor shall restore any existing tile blowout areas to allow these areas to be farmed following construction. Of note in this area is the blowout at station A0+147. Contractor to be aware of the low-lying grassed lands from station A0+167 to station A0+182 and shall restore the areas to allow them to be easily farmed following construction.
A0+265 to A0+424	<ul style="list-style-type: none"> Depth from existing ground to the proposed tile invert elevation exceeds 2.5m through a portion of this length. From approximate station A0+330 to station A0+410. The proposed drain alignment does not follow the existing Branch A or Branch C, and the existing tile is not proposed to be destroyed as a part of this project. A 45°, 400mmØ HDPE elbow to be installed at approximately station A0+353. The concrete tile both upstream and downstream of the elbow shall be butt-jointed to the HDPE elbow. Both elbow joints shall be double-wrapped with geotextile.
A0+424 to A0+502	<ul style="list-style-type: none"> Sealed, bell & spigoted and gasketed, HDPE pipe to be installed through this length. Care to be taken by the Contractor to minimize the disturbance from construction activities through this wetland area. A 22.5°, 375mmØ HDPE elbow to be installed at approximately station A0+499.
Branch B	
B0+000 to B0+063	<ul style="list-style-type: none"> Solid, split coupler, HDPE pipe to be installed through this length. The existing Municipal drain shall be destroyed in place in its entirety along this length. Tree removals are required through this length. Contractor to ensure organic material such as tree roots are absent from the trench backfill.

All of the aforementioned work shall be included as part of the work of the associated tile installation line item. An extra payment will not be made for the stripping, stockpiling and replacing of topsoil.

The Contractor shall be responsible for any damage to the new tile throughout the warranty period.

Provisional Items Associated with Tile Installation

The Contractor shall bid the installation of the new pipe on the basis of using the specified installation technique; however, as specified in the provisional items, the Contractor shall provide additional unit prices for instances that may require transition to a different installation technique.

SP7 Structure Installation

The proposed catchbasins and junction boxes shall be manufactured with cored holes, knockouts, and sumps as per the applicable structure details. Structures shall be oriented, and grading surrounding all structures completed as per the accompanying drawings. Any existing structures in the general vicinity of a proposed structure shall be removed and disposed of offsite by the Contractor unless specified otherwise. The Contractor shall include the cost to complete all necessary tile connections c/w parging on the interior and exterior of the proposed structure as part of the associated line item.

All catchbasins shall have a minimum 300mm deep sump unless specified otherwise.

All catchbasins shall be cast in sections and include a minimum one 50mm to 150mm riser to allow for adjustment of the top elevation during construction to account for the field conditions. All catchbasin sections shall be wrapped with a minimum 400mm thickness of RM-150 (4 oz.) non-woven geotextile or approved equivalent.

All ditch inlet catchbasins (DICBs) shall have a 2H:1V slope if they are a 600mm x 600mm DICB and a 3H:1V slope if they are a 900mm x 1,200mm DICB.

Junction boxes shall have a minimum 150mm thick reinforced concrete lid and shall have a minimum 450mm of cover.

All structures shall be placed on either firm native material, or if necessary, 19mm clearstone bedding. All structures shall be levelled by the Contractor to the satisfaction of the Contract Administrator. Excavated subsoil material may be used by the Contractor as backfill surrounding the catchbasins, however the Contractor shall be responsible to address any settlement around the structure during the warranty period.

The Contractor shall supply and place a minimum 1m width of rip-rap with geotextile on all sides of all catchbasins and install each catchbasin with tabs, and approved post and marker. All catchbasins shall be topped with a birdcage type steel grate which shall be removable and shall be inset into a recess around the top of the structure.

The following specific notes shall be considered by the Contractor in their bid of the associated line item:

DICB at Station 0+478 – The Contractor shall supply & install approx. 6m of 375mmØ solid, HDPE pipe (320 kPa) and one 375mm dia. 45 degree HDPE elbow (320 kPa) for the connection of the existing Municipal drain. The elbow shall only be connected to HDPE pipes and the plain end of the

pipe shall be inserted into each bell end of the elbow. The joint between the existing CDT and the proposed pipe shall be butt jointed and double wrapped with a minimum 400mm width of geotextile. All existing municipal tile destroyed in the making of this connection shall be disposed of offsite by the Contractor. The connection shall be properly supported with 19mm clearstone to the satisfaction of the Contract Administrator.

CB at Station A0+265 – The Contractor shall supply & install a approx. 3m of 300mmØ solid, plastic ag. tubing for the connection of the existing Branch A drain. The joint between the existing CDT and the proposed pipe shall be butt jointed and double wrapped with a minimum 400mm width of geotextile. All existing private tile destroyed in the making of this connection shall be disposed of offsite by the Contractor. The connection shall be properly supported with 19mm clearstone to the satisfaction of the Contract Administrator.

CB at Station B0+081 – The Contractor shall supply & install approx. 3m of 200mmØ solid, plastic ag. tubing for the connection of an existing private drain. The joint between the existing CDT and the proposed pipe shall be butt jointed and double wrapped with a minimum 400mm width of geotextile. All existing private tile destroyed in the making of this connection shall be disposed of offsite by the Contractor. The connection shall be properly supported with 19mm clearstone to the satisfaction of the Contract Administrator.

SP8 Seventh Concession Road Open Cut Crossings

The crossings shall be as constructed as per the accompanying drawings and details.

Notification. The Contractor shall give the Authority responsible for the lands being crossed a minimum seven days' notice before they commence any work on the crossing and shall provide a traffic control plan for review by the Authority at that time. The plan shall be approved by the Owner prior to the beginning of construction. This information shall be provided to Braeden Robinson at the County of Brant (email: braedan.robinson@brant.ca, phone: (519) 732 – 5649))

Traffic Control. The Contractor shall be responsible for providing, erecting, maintaining and removing all signage and traffic control in accordance with the Ontario Traffic Manual (OTM) and the OTM Book 7 Temporary Conditions – Field Edition. Any required traffic control measures shall be the responsibility of the Contractor and the cost of the traffic control is to be included in the bid price for the crossing.

Construction. The Contractor shall strip all topsoil material that will be disturbed in the completion of the crossing. This material shall be stockpiled separately from the subsoil material. The Contractor shall note dewatering requirements noted in the General Specification for the crossing installation works.

The existing pipe shall be removed and disposed of off-site by the Contractor. All unsuitable or excess material shall be spread and levelled within the working ROW to the satisfaction of the Contract Administrator.

APPENDIX A – CONSTRUCTION SPECIFICATIONS

The Contractor shall be responsible for all equipment, labour and material costs associated with temporary excavations (i.e. shelf construction within the crossing), access crossings, etc. required to facilitate the construction works. The Contractor shall restore any of these locations to existing conditions or better once they are no longer necessary.

The Contractor shall complete all trenching required to install the pipe with slopes as per OPSD 802.010. The Contractor shall stockpile the existing granular material separately from the native subsoil material in the crossing for re-use in the crossing. If the native subsoil material is not suitable for re-installation in the roadway, Granular 'B' material shall be imported and paid for as a provisional item.

The Contractor shall bed the pipe on a minimum 150mm thickness of 19mm dia. clear crushed stone or Granular 'A' material compacted to a minimum 98% Standard Proctor Dry Density (SPDD). The Contractor shall install the bedding material a minimum 300mm in thickness around the edges and top of the pipe at a minimum. The Contractor shall use select native material, or if required, imported Granular 'B' material be used as backfill within the crossing and be paid for as a provisional item. The Contractor shall place the material in lifts no greater than 300mm in depth, and shall compact each lift with an approved vibratory plate compactor to a minimum 98% SPDD prior to the next lift being placed. Compacted backfill material shall extend a minimum 1m from the edge of the crossing projecting downwards at a 1H:1V slope at a minimum. The Contractor shall provide a minimum 150mm topcoat depth of Granular 'A' compacted to 98% SPDD. The final top width of the crossing shall match the existing crossing.

Should Granular 'B' be required to be imported to the site, only the additional labour time resulting for levelling the excess spoil in the working ROW, or trucking away the excess spoil shall be considered to be extra work and shall be negotiated at the time of construction. These extras shall only apply from the imported Granular 'B' displacing existing native material and shall not apply for the spoil levelling/trucking that will be required from the native material displaced by the proposed pipes, imported bedding material, topcoat of Granular 'A' material, etc.

Any settlement or deficiency with the crossing shall be the sole responsibility of the Contractor. The Owner of the crossing shall be contacted by the Contractor regarding any issues pertaining to the pipe installation on their property, prior to leaving the site. Any issues shall be remedied to the satisfaction of the Contract Administrator and Owner.

Restoration. All stockpiled topsoil shall be spread and levelled in the disturbed vegetation areas at the conclusion of construction works. Following topsoil restoration with the stockpiled material, disturbed areas that were previously grassed shall be seeded as per the General Requirements.

The finished work shall be left in a clean and orderly condition flush or slightly higher than the adjacent ground so that after settlement it will conform to the surrounding ground.

SP9 Seeding

All grass seed shall be as per the General Requirements.

Following the completion of construction work, all areas that were previously grassed, and the newly excavated channel banks shall be handseeded by the Contractor to the satisfaction of the Contract Administrator.

SP10 Tile Connections

For the unit bid price, the Contractor shall provide all labour and material required to connect all any private drains encountered during construction to the proposed drain with appropriately sized agricultural tubing or approved equivalent (assuming a length of 6m or less). Initially the Contractor shall connect to the existing tile with an appropriate coupler or reducer. The connection shall be adequately supported with 19mm clear stone bedding and the stone shall be paid out based on the bid unit price in the Tender and not included in the bid of this line item. Connections directly to a length of tile shall be installed into the drain with a core drilled hole and manufactured HDPE tee/coupler fitting as per the detail in the accompanying drawings. Connections directly to a structure shall be into the appropriate opening/knockout provided, and parged on the interior and exterior of the structure.

The Contractor shall also cap the downstream end of the connected tile with an end cap, geotextile, or other item to the satisfaction of the Contract Administrator.

The Contractor shall be responsible for all tile connections made, or any missed tile connections over the course of the warranty period, and is required to rectify any deficiencies related to the connections.

SP11 Supply and Install Granular 'B'

For the unit price bid per tonne, the Contractor shall supply Granular 'B' Type I, II, or III material as per the requirements in OPSS.MUNI 1010. These unit prices shall be used for payment for any Granular 'B' material installed in addition to those quantities already specified in other items and for credit for any quantities of Granular 'B' deleted from other items.

The Contractor shall then install the granular material as directed by the Contract Administrator.

SP12 Special Installation Technique

If poor construction conditions are encountered during construction where, in the opinion of the Contractor, it is not feasible to install tile via excavator as per the typical installation technique on the accompanying details, the Contractor shall immediately inform the Contract Administrator to obtain approval to switch to:

APPENDIX A – CONSTRUCTION SPECIFICATIONS

- Installation on a minimum depth of 300mm of geotextile wrapped 19mm dia. clear crushed stone (or approved equal) with 19mm clear crushed stone backfill up to the springline of the pipe at a minimum.

The Contractor shall bid the additional unit price bid per lineal metre of trench, including all additional labour, equipment and materials (excluding the supply cost of 19mm clearstone) required, to install the pipe on geotextile wrapped 19mm ($\frac{3}{4}$ inch) diameter clear crushed stone, as described in the schedule of unit prices per the detail in the accompanying drawings, with a hydraulic excavator. The supply cost of the 19mm clearstone shall be paid based on the bid unit price in the Tender and not included in the bid of this line item. The Contractor shall note that the wrapping of tile joints still applies under original items.

The Contractor shall keep a list of stations where this installation technique is used, to be confirmed with the Contract Administrator on a daily basis.

This item shall be used only when the soil conditions encountered are such that the typical installation technique with an excavator cannot, in the opinion of the Contract Administrator, be used effectively to install the pipe. The Contractor must receive approval from the Contract Administrator prior to using this technique. When soil conditions are again favourable in the opinion of the Contractor and the Contract Administrator, typical installation techniques shall resume as soon as possible. Failure to do so may result in non-payment of this provisional item.

2 General Requirements

2.1 Periodic and Final Construction Review

Periodic review of the construction works will be made by the Contract Administrator during the completion of the work. The Contract Administrator may order the Contractor to daylight any aspect of the work completed so that they may verify elevations, or review any other aspect of the work.

Regardless of whether or not the Contractor's work has been checked by the Contract Administrator, the Contractor shall assume full responsibility for the alignment, elevations, and dimensions of each and all parts of the work.

Prior to demobilization and removal of equipment and materials from the site, the Contractor shall arrange an on-site final review of the work with the Contract Administrator. A minimum 48 hours' notice shall be provided by the Contractor.

2.2 Existing Conditions

The Contractor shall clean up and restore all disturbed areas to condition equal to or better than existing conditions using materials equal to or better than existing materials.

The Contractor shall maintain flow in all existing sewers, drains, ditches, watercourses, etc. as applicable.

2.3 Benchmarks and Temporary Construction Markers

The established benchmarks will govern the elevation of the proposed work and the Contractor shall verify the accuracy of benchmarks prior to completing any construction works. Any discrepancies shall be brought to the attention of the Contract Administrator immediately.

Both prior to and during construction, the Contract Administrator may set out temporary benchmarks, stakes, flags, or markers. The Contractor or property owner shall be held liable for the cost of re-establishing any destroyed benchmarks or temporary construction markers.

2.4 Material Specifications

Unless otherwise specified elsewhere in the Contract Documents the following specifications shall apply for the following construction materials.

- All concrete tile shall conform to the requirements of the most recent ASTM C412 specification for with a pipe strength of 2000D.
- All high-density polyethylene (HDPE) pipe shall be solid dual-wall (i.e. smooth inner wall) pipe with a minimum stiffness of 320 kPa at 5% deflection. The pipe joints shall be secured with either snap-on couplers for pipes up to and including 200mm in diameter, or split couplers for pipes larger

than 250mm in diameter, or gasketed bell and spigot joints, whichever is specified in the Contract Documents.

- All agricultural tubing shall be corrugated inner and outer wall tubing conforming to the Land Improvement Contractors of Ontario – Standard Specification for Corrugated Plastic Drainage Tubing, 2006. Requirements for the tubing to be perforated or wrapped in a sock will be specified in the Contract Documents.
- All non-woven geotextile shall be RM-150 (4 oz), Terrafix 270R or approved equivalent unless specified elsewhere.
- Granular 'A' material shall be as per requirements in OPSS.MUNI 1010.
- Granular 'B' material shall be as per requirements in OPSS.MUNI 1010 and be assumed to be Type I, II, or III Granular 'B' material.
- 19mm ($\frac{3}{4}$ inch) crushed clear stone shall be as per requirements in OPSS.MUNI 1004.
- Rip-Rap shall be as per requirements in OPSS.MUNI 1004 and be assumed to be R-50 classification (generally ranging from 100mm to 300mm in diameter).

2.5 Iron Bars

The Contractor shall notify the Contract Administrator should they disturb an iron bar during construction so it can be replaced by an Ontario Land Surveyor. If, to the discretion of the Contract Administrator, the disturbance of the iron bar is due to negligence on the Contractor's behalf, the Contractor shall retain an Ontario Land Surveyor to replace the bar at their own expense.

2.6 Pollution

The Contractor shall keep their equipment in good repair. The Contractor shall refuel or repair equipment away from open water.

If polluted material from the construction materials or equipment is caused to flow into the drain, the Contractor shall immediately follow the relevant spill reporting and cleanup protocols specified by the relevant governing body.

2.7 Fences

The Contractor will be permitted to remove fences to the extent necessary to allow for the construction of the drain. Unless specifically noted in the Contract documents, disturbed fences shall be restored in as good of condition as they were found. Fences should be handled in such a manner to prevent any unnecessary damage. Where feasible, cutting of the fence and subsequently patching the fence shall be avoided. The Contractor shall not leave any fence open when not working in the immediate area and shall replace the fence in a timely manner.

Fences damaged beyond repair as a result of the Contractor's negligence shall be replaced with new materials similar to the existing fence to the satisfaction of the Contract Administrator, and all costs incurred shall be at the Contractor's expense.

2.8 Livestock and Standing Crops

The Contractor shall notify all property owners with a minimum 48 hours' notice prior to removing a fence that may contain livestock, or prior to damaging to any standing crops. The Contractor shall be responsible for all loss or injury of livestock, or damage to crops if they fail to provide 48 hours' notice to the relevant property owner.

Following notification, the property owner shall be responsible to keep the livestock clear of the construction activities until all such activities have concluded.

2.9 Material Disposal

The Contractor is responsible to remove and dispose of all excess construction materials off-site prior to demobilizing from the site.

2.10 Removal of Large Stones and Rock

The Contractor shall haul all stones greater than 300mm in diameter that remain at the ground surface following construction to a location approved by the property owner or, if there is no suitable location, disposed of off-site. Extra costs for such stone relocation/removal shall be to the discretion of the Contract Administrator.

2.11 Damage by Vehicles and Other Equipment

Throughout all construction activities, the Contractor shall be responsible maintain all road surfaces impacted by the construction activities. This maintenance shall include but not be limited to scraping mud from the road surfaces, repairing potholes, etc.

If at any time, in the opinion of the Contract Administrator, damage is being or is likely to be done to any road or other infrastructure that is not included in the scope of work, by the Contractor's vehicles or other equipment, the Contractor shall, on the direction of the Contract Administrator and at the Contractor's own expense make changes in or substitutions for such vehicles or other equipment or shall in some manner remove the cause of such damage to the satisfaction of the Contract Administrator.

2.12 Equipment and Material Staging

Construction equipment and materials shall be staged in the areas specified in the Contract Documents. No construction equipment or materials shall be left unattended within five (5) metres of any road ROW.

2.13 Deficient Items

Deficient items as noted by the Contract Administrator shall be remedied by the Contractor in a timely manner. The Contract Administrator shall, at their discretion, have the authority to holdback up

to **250%** of the value of a deficient item. If the deficient item is not remedied in a reasonable time frame, the Contract Administrator shall notify the Contractor, and, at the Contract Administrator's discretion, procure an alternative Contractor to complete the work and any outstanding payment associated with the deficient item shall be forfeited by the original Contractor.

2.14 Construction Document Errors

The Contractor shall notify the Contract Administrator immediately with respect to any errors or omissions with any of the construction contract documents. The Contractor shall be responsible for any decisions they make of their own accord to correct such errors or omissions and no extra charge shall be incurred because of said decisions.

The Contractor and Contract Administrator shall, in a timely manner, rectify the errors and omissions and adjust the contract documents as the situation warrants.

2.15 Alterations to Work

The Contract Administrator shall have the power to make alterations in the work and the Contractor shall proceed to make such changes without causing delay. Such alterations shall in no way render the Contract void.

The valuation of such alterations shall be determined as a result of negotiations between the Contractor and Contract Administrator, but in all cases the Contract Administrator shall maintain the final responsibility for the decision. Where such changes involve additional work similar to other items in the Contract, the price for the additional work shall be determined after consideration is given to the bid price for similar items.

Furthermore, in the event that the quantity of any provisional item exceeds the quantity specified in the Bid Form by more than 150%, the Contract Administrator may request revised unit pricing resulting from economies of scale, and the Contractor shall provide updated unit pricing within one (1) working day.

No claims for a variation or alteration in the increased or decreased price shall be valid unless done in pursuance of an order form from the Contract. In no case shall the Contractor commence work that they consider to be an extra charge before receiving approval from the Contract Administrator.

2.16 Liquidated Damages

It is agreed by the parties to the Contract, that if this Contract is not substantially performed by the required date specified in the Contract Documents without prior consultation with the Contract Administrator and Owner, that the Contractor may be subject to **daily liquidated damages of \$500 plus HST** for each and every calendar day's delay in finishing the work to the discretion of the Contract Administrator and Owner.

2.17 Sub-Contractors

The Contractor shall not sublet the whole or part of this Contract without the approval of the Contract Administrator.

2.18 Payment

Progress payments equal to 87% of the value of work completed and materials incorporated shall be made to the Contractor on a monthly basis. The remaining 13% of the work completed shall consist of a 10% Statutory Holdback and a 3% Warranty Holdback for the project.

Payments shall be made on the written request and submission of a proper invoice by the Contractor to the Contract Administrator or Owner. A proper invoice submission, in addition to the definition provided in the Construction Act shall require the following:

- Quantities and unit prices shall be provided for with adequate supporting documentation shall be provided by the Contractor for all necessary items. For extras in the Contract, the Contract Administrator may request a detailed labour and material breakdown.
- A current clearance certificate from the Workplace Safety and Insurance Board (WSIB).
- A detailed unit summary page denoting all payable line items, applicable holdbacks, taxes, etc.

If any of these requirements are not met to the satisfaction of the Contract Administrator, the Contract Administrator shall promptly notify the Contractor, at which time the Contractor shall revise the invoice. Prompt payment procedures shall not begin until the Contract Administrator receives a proper invoice to the satisfaction of the Contract Administrator.

2.19 Project Completion/Substantial Performance

For all intents and purposes, for this project, the substantial performance date shall be deemed to be the same as the completion date of the project and any documentation indicating such shall represent both the date of substantial performance and project completion. Substantial performance shall be determined as per its definition in the Construction Act.

2.20 Statutory Holdback

As per the Construction Act, a 10% Statutory Holdback shall not be due until 60 days from the date of Substantial Performance. This payment shall be released once the Contractor provides a Statutory Declaration that all material and/or labour incorporated in the work has been fully paid for.

2.21 Warranty Holdback

A 3% Warranty Holdback shall not be paid for a minimum one year from the date of Substantial Performance. If the Contract Administrator notifies the Contractor in writing of any deficient items prior to the expiration of the warranty period, they shall be remedied promptly by the Contractor notwithstanding that the rectification of the work may extend beyond the end of the warranty period.

The warranty holdback shall not be considered due until all outstanding deficient items have been rectified by the Contractor to the satisfaction of the Contract Administrator.

2.22 Tests

The cost for testing of materials supplied to the job by the Contractor shall be borne by the Contractor.

The Contract Administrator shall have the authority to subject any lengths of any pipe to a competent testing laboratory to ensure the adequacy of the pipe. If any pipe supplied by the Contractor is determined to be inadequate to meet the applicable governing standards, the Contractor shall bear the full responsibility to remove and/or replace all such inadequate pipe with pipe that satisfies the requirements of said governing standards.

2.23 Species at Risk

The Contractor is responsible to ensure that during construction, no extirpated, endangered, threatened, or special concern species or their habitats are adversely affected. Should a Species at Risk be encountered, the Contractor shall notify the Contract Administrator immediately and follow the Ministry's guidelines and guidance regarding handling of the species, measures to exclude the species from the site, safety considerations, etc.

2.24 Weather

The Contractor shall make every effort to avoid working in weather conditions that may increase the difficulty of construction activities. Should the Contractor choose to work during periods of frequent rainfall or snow, or excessively hot or cold weather, etc., extra charges resulting from working in unfavourable construction conditions caused by such weather may not be applicable and shall be to the discretion of the Contract Administrator.

2.25 Dewatering

The Contractor shall dewater excavations/trenches and maintain the groundwater level at least 0.5m below the excavation bases, thereby facilitating proper completion of the work in reasonably dry, stable conditions. If a specific line item for dewatering is not included with the Contract, the cost of such dewatering shall be included with the bid of the associated line items and no additional payments shall apply if the Contractor is required to complete damming, pumping, etc. in order to facilitate construction works.

The dewatering system shall be discharged a minimum 20m away from its re-entry point to the drain to encourage water filtration. The quality of the water re-entering the watercourse shall be to the satisfaction of the Contract Administrator and should additional means be required to ensure suitable water quality (i.e. filter bags, settling ponds, check dams, geo-textile, etc.), they shall be negotiated as an extra item at the time of construction.

2.26 Erosion and Sediment Control

Appropriate erosion and sediment control measures shall be in place for the entirety of construction and the Contractor shall regularly monitor and maintain said measures. The Contractor shall ensure that the site is left each day with appropriate controls to avoid erosion. No construction activities which may cause sediment to be conveyed downstream of the working area shall commence until appropriate erosion and sediment control measures are in place.

2.27 Seeding

Grass seed shall be fresh, and clean seed, and unless specified elsewhere be as per OPSS.MUNI 804 Standard Roadside Mix which is duplicated below for convenience. It shall be applied at a rate of 130kg per 10,000m²:

- 50 % Creeping red fescue
- 10% Kentucky Bluegrass
- 35% Perennial Ryegrass
- 5% White clover

If a nurse crop is required, it shall be fall rye grain or winter wheat grain applied at a rate of 60 kg per 10,000m².

3 General Specifications for Open Drains

3.1 Profile

The profile drawing shows the approximate depth of cuts from the base of the existing open drain to the proposed base of the drain as well as the total existing depth of the open drain. These cuts are established for the convenience of the Contractor, however, benchmarks will govern the final elevation of the drain. Accurate grade control must be maintained by the Contractor during the work in the open drain to the satisfaction of the Contract Administrator.

3.2 Tile Outlets

During any construction activities on an open drain, the Contractor shall guard against damaging the outlet of any private or municipal pipes that outlet into the open drain.

Repair or replacement of any tile outlets shall be as per the accompanying drawings. Any marked tile drain outlets damaged during construction shall be repaired by the Contractor at their own expense. Any unmarked tile drain outlets damaged during construction shall be repaired by the Contractor and paid as a provisional item.

3.3 Crossing of Open Drains

No crossing of any drain, watercourse, or other waterbody with construction equipment shall be permitted throughout the duration of construction. Should a temporary crossing be required it shall be on a bed of rip-rap or a temporary crossing with an appropriately sized culvert shall be constructed by the Contractor. The Contractor shall be responsible for the failure of the temporary crossing or if any deleterious substances are released as a result of inadequacies with the temporary crossing.

The Contractor shall remove all materials associated with the temporary crossing when it is no longer required and restore the channel to its undisturbed conditions or better to the satisfaction of the Contract Administrator.

4 General Specifications for Tile Drains

4.1 Alignment

The Contractor shall contact the Contract Administrator to establish the approximate course of the drain at the onset of construction and provide a minimum 48 hours' notice to do so. The drain shall run in as straight a line as possible throughout its length.

Where an existing drain is to be removed and replaced by the new drain, or where the new drain is to be installed parallel to the existing drain, or between two runs of existing drains, the Contractor shall locate the existing drain(s) at intervals along the course of the drain such that the disturbance of any existing drainage systems is minimized. The frequency of drain locating shall be to the discretion of the Contractor and should be generally more frequent in areas where the existing drain is turning to avoid disturbance of the existing system. The costs of locating shall be included in the bid price and the Contractor shall be responsible to repair any tiles that are damaged during the drain locating at no additional cost.

4.2 Profile

The profile drawing shows the elevations and gradients that the tile drain shall be installed at as well as the approximate depth of cuts from the existing ground elevation to the proposed invert of the pipe in key locations. The cuts are noted for the convenience of the Contractor, however, benchmarks will govern the final elevation of the drain. Accurate grade control must be maintained by the Contractor during the installation of any tile drains to the satisfaction of the Contract Administrator.

When installing a drain towards a fixed point such as a previously installed bore pipe, the Contractor shall confirm the elevations of such a fixed point at a sufficient distance away from the pipe in order to allow for any minor adjustments to the pipe grade as required.

4.3 Trench Crossings

The Contractor shall not cross any backfilled trench with any construction equipment, except at one designated crossing location on each property. The Contractor shall ensure that the bedding and backfill material at this designated crossing location is properly placed and compacted to adequately support the equipment and vehicles that may cross the trench. The Contractor shall be responsible for any damage to the new tile resulting from the crossing of the drain.

Appendix B
Drawings

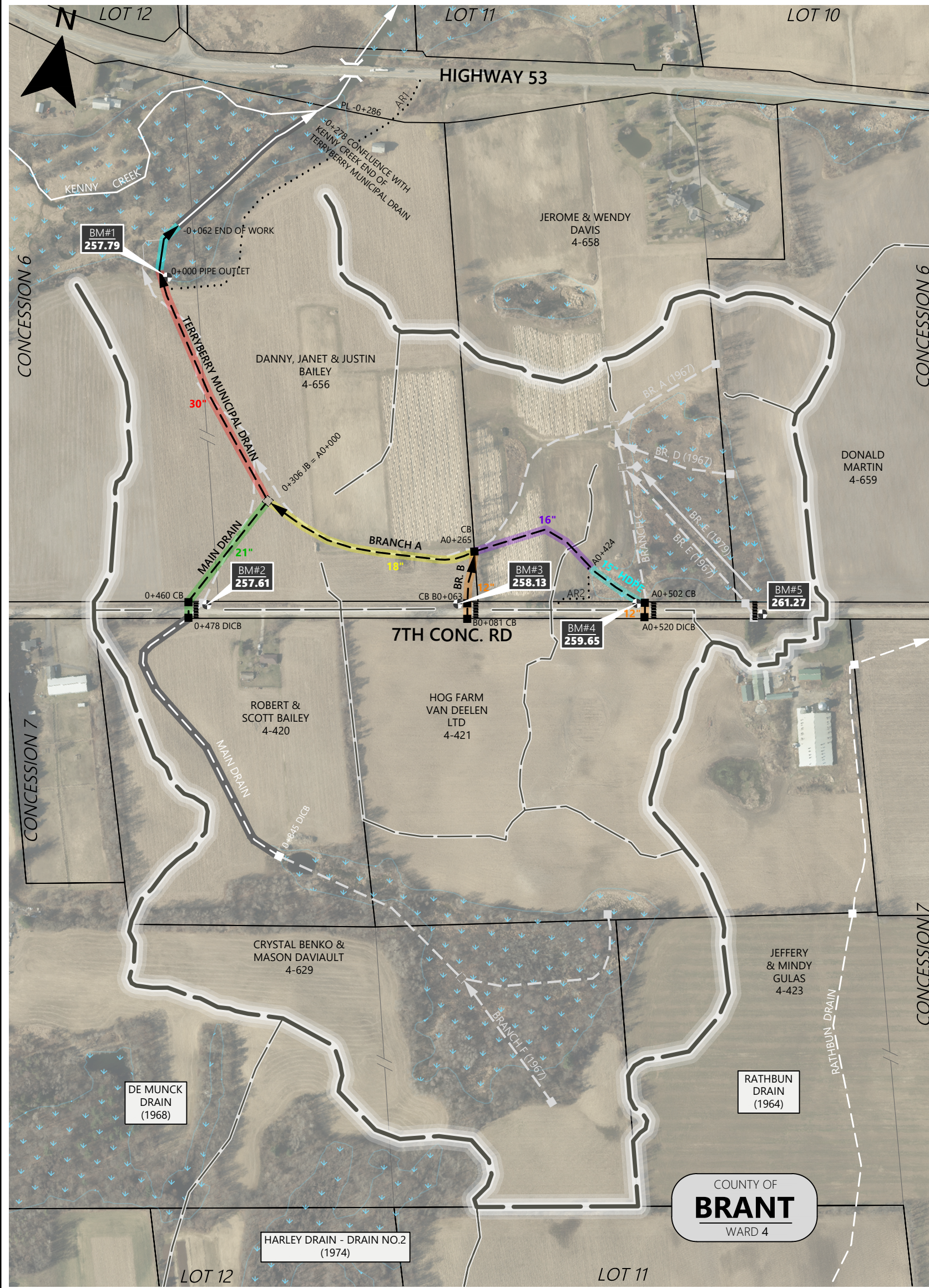

WATERSHED PLAN

SCALE 1:5,000
0 50 100 200 300m

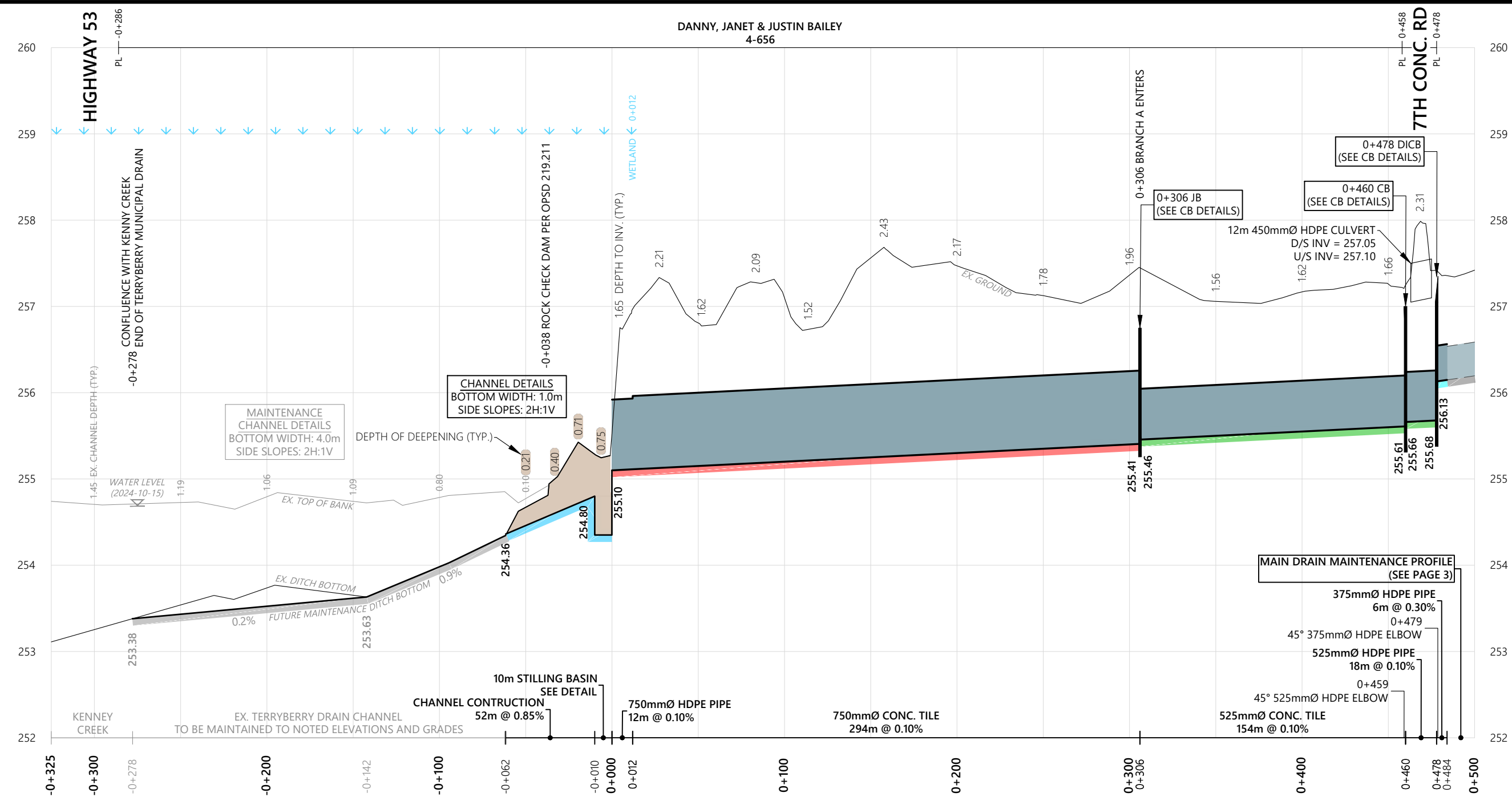

MAIN DRAIN PROFILE

SCALE H1:2500 | V1:50

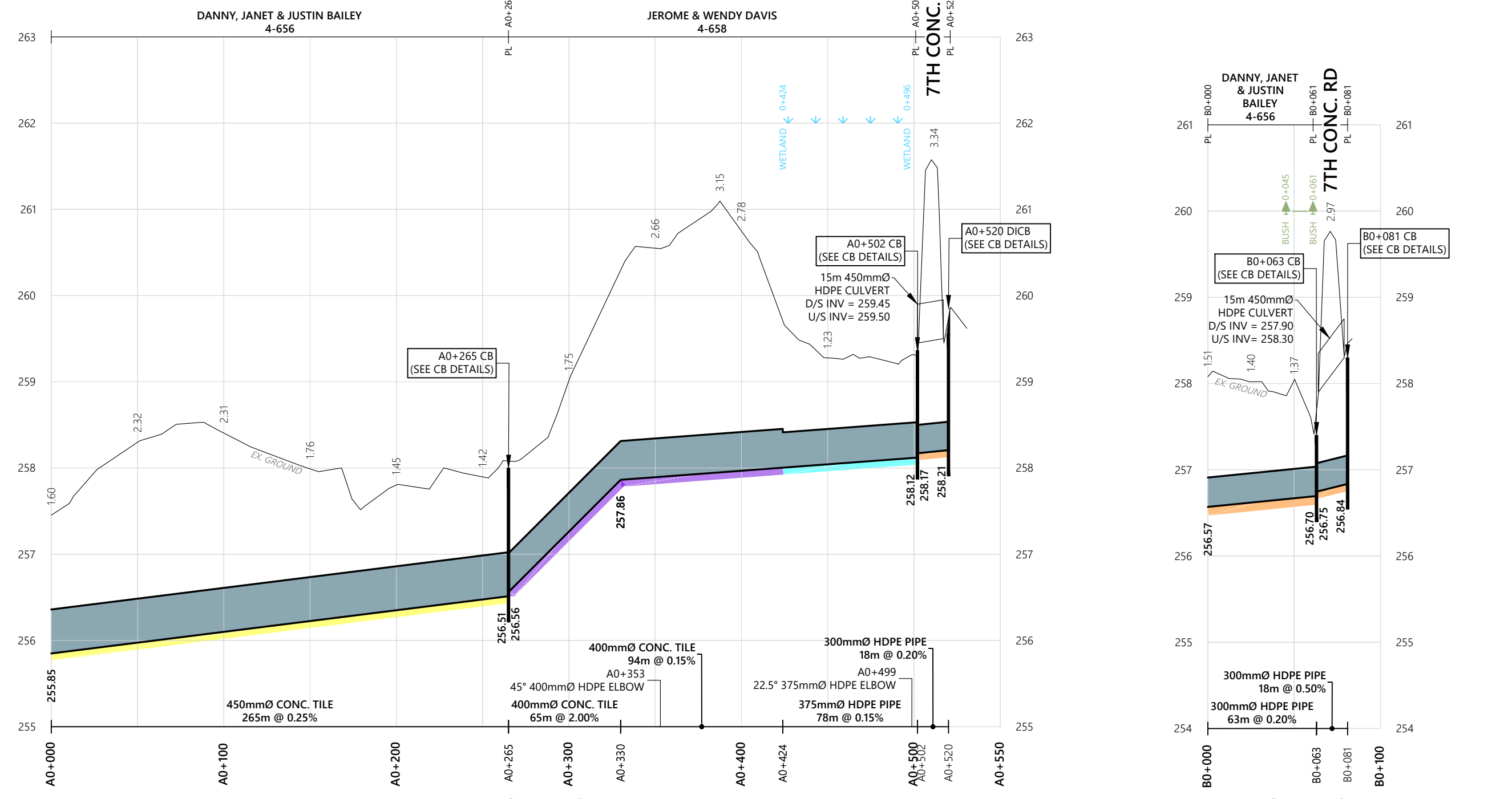

BRANCH A PROFILE

SCALE H1:2500 | V1:50

BRANCH B PROFILE

SCALE H1:2500 | V1:50

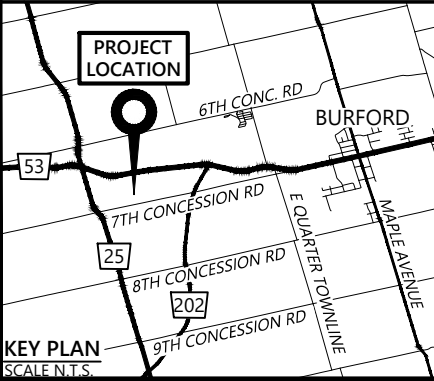

LEGEND	
WATERSHED BOUNDARY	PR. OPEN DRAIN
SUBWATERSHED BOUNDARY	EX. OPEN DRAIN
APPROX. PROPERTY LINE	FUTURE MAINT. OPEN DRAIN
PROPERTY SHARED BETWEEN LOT LINES	BENCHMARK LOCATION, NUMBER, & ELEVATION
PR. TILE	PR. CATCH BASIN
EX. TILE	EX. CATCH BASIN
FUTURE MAINT. TILE	PR. JUNCTION BOX
PR. SURFACE CULVERT	EX. JUNCTION BOX
	ACCESS ROUTE PATH
	PROVINCIAL SIGNIFICANT WETLAND AREA
	EX. DRAIN CROSSING

BENCHMARKS	
BENCHMARK No. 1 NAIL IN 400mmØ DECIDUOUS TREE APPROX. 5m NORTH OF FIELD EDGE AND APPROX. 30m EAST OF EXISTING OUTLET. APPROX. 10m SOUTH EAST OF PROPOSED TILE OUTLET AT STA. 0+000.	ELEVATION=257.79m
BENCHMARK No. 2 NAIL IN HYDRO POLE WITH ID# AWTRCY ON NORTH SIDE OF 7TH CONCESSION ROAD, LOCATED APPROX. 20m EAST OF STA. 0+460 NEAR EXISTING MAIN DRAIN CROSSING. APPROX. 500m EAST OF INTERSECTION BETWEEN 7TH CONCESSION ROAD AND REGIONAL ROAD 25.	ELEVATION=257.61m
BENCHMARK No. 3 NAIL IN HYDRO POLE WITH ID# AWTSXD ON NORTH SIDE OF 7TH CONCESSION ROAD, APPROX. 5m WEST OF STA. B0+063, NEAR EXISTING BRANCH B CROSSING. APPROX. 800m EAST OF INTERSECTION BETWEEN 7TH CONCESSION ROAD AND REGIONAL ROAD 25.	ELEVATION=258.13m
BENCHMARK No. 4 NAIL IN HYDRO POLE WITH ID# AWTSUP ON NORTH SIDE OF 7TH CONCESSION ROAD, APPROX. 5m EAST OF STA. A0+502, NEAR EXISTING BRANCH C CROSSING. APPROX. 1000m EAST OF INTERSECTION BETWEEN 7TH CONCESSION ROAD AND REGIONAL ROAD 25.	ELEVATION=259.65m
BENCHMARK No. 5 NAIL IN HYDRO POLE WITH ID# CDT4FN ON SOUTH SIDE OF 7TH CONCESSION ROAD, APPROX. 5m EAST OF EXISTING BRANCH E CROSSING. NEAR PROPOSED CULVERT. APPROX. 150m EAST OF INTERSECTION BETWEEN 7TH CONCESSION ROAD AND REGIONAL ROAD 25.	ELEVATION=261.27m



TERRYBERRY MUNICIPAL DRAIN IMPROVEMENT 2025

STREAMLINE ENGINEERING INC.

CLIENT: COUNTY OF Brant Simply Grand

ISSUE / REVISION	DATE
FOR ON-SITE MEETING	OCT 2024
FOR INFO MEETING	NOV 2024
FOR ENGINEER'S REPORT	JAN 2025

DRAWING: **PLAN & PROFILES**

DESIGNED: MS/CK DRAWN: MS/CK CHECKED: TK PROJECT NO: 0015

DRAWING NO: **1** OF **3**

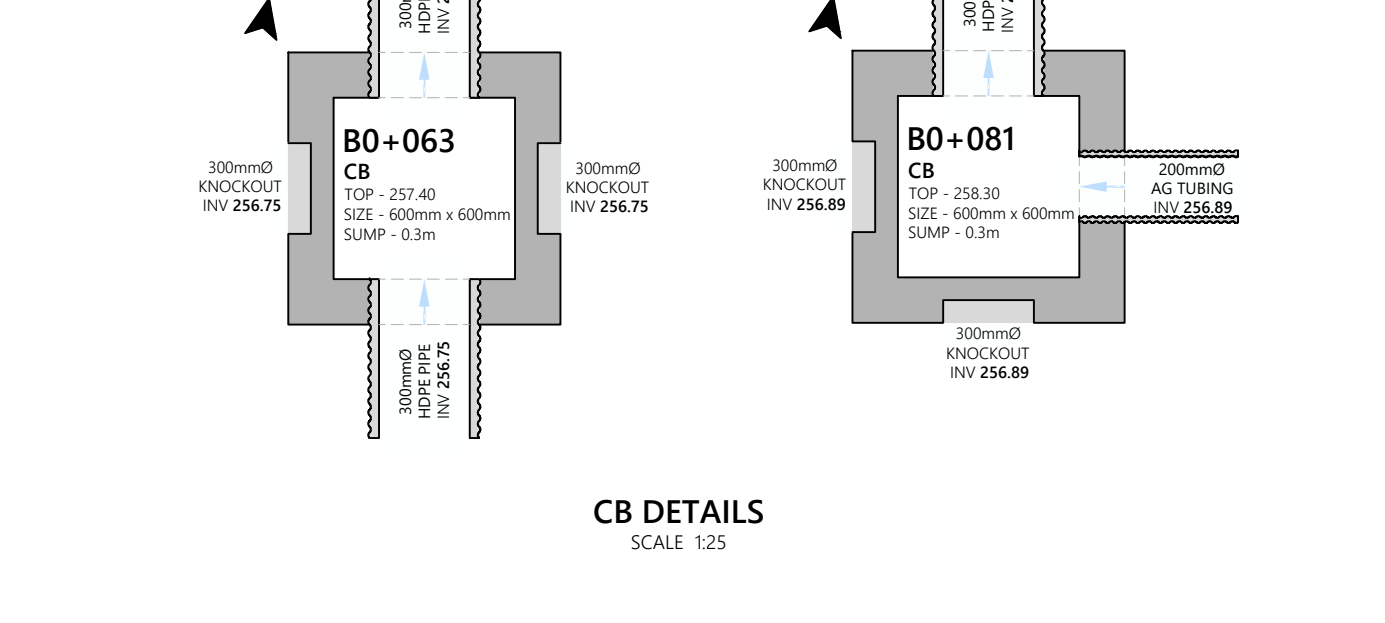
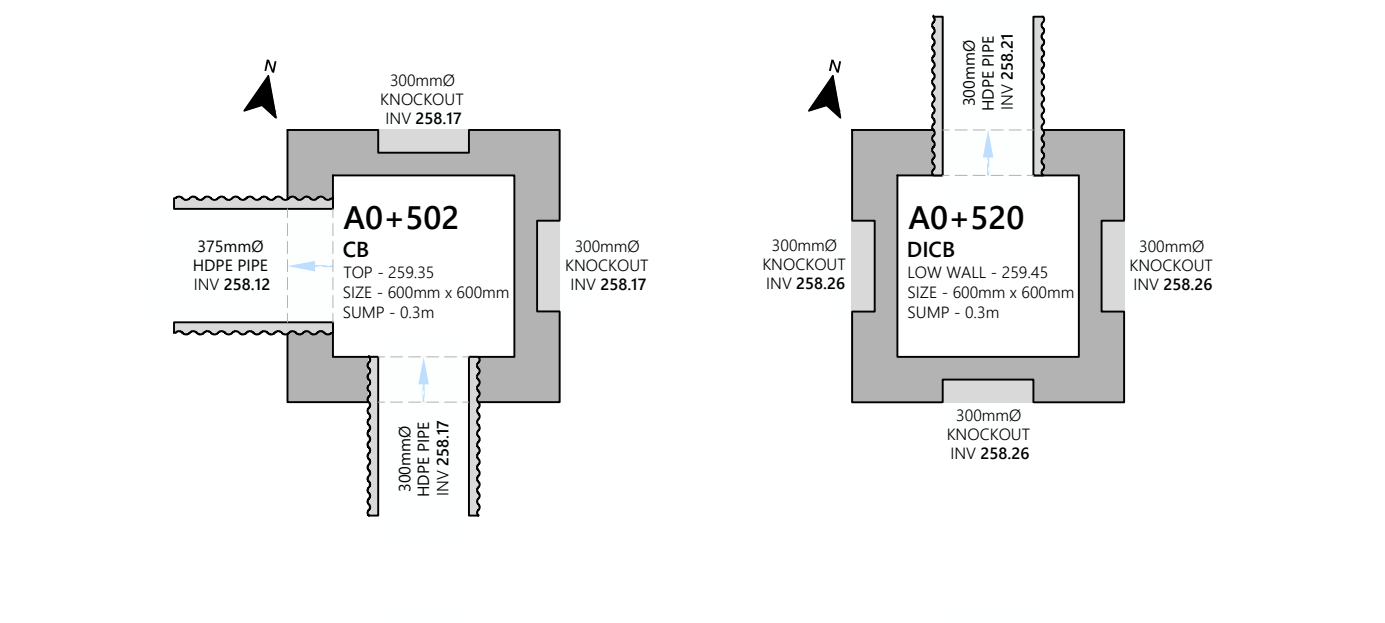
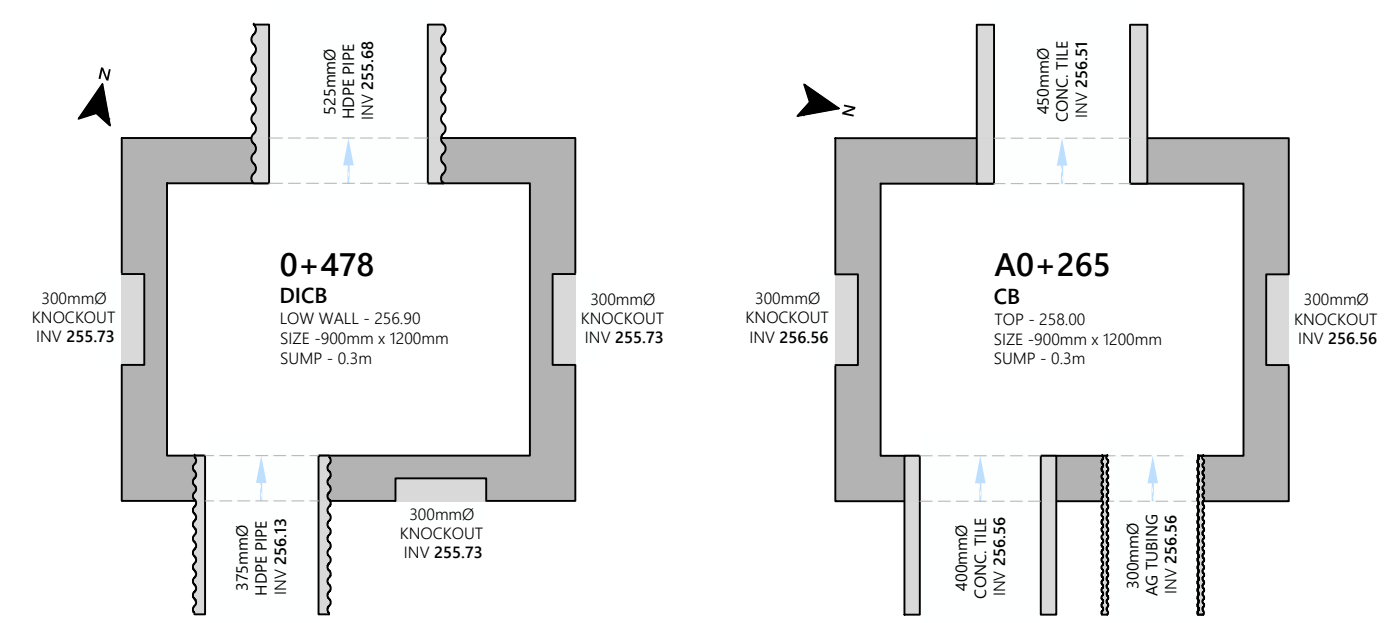
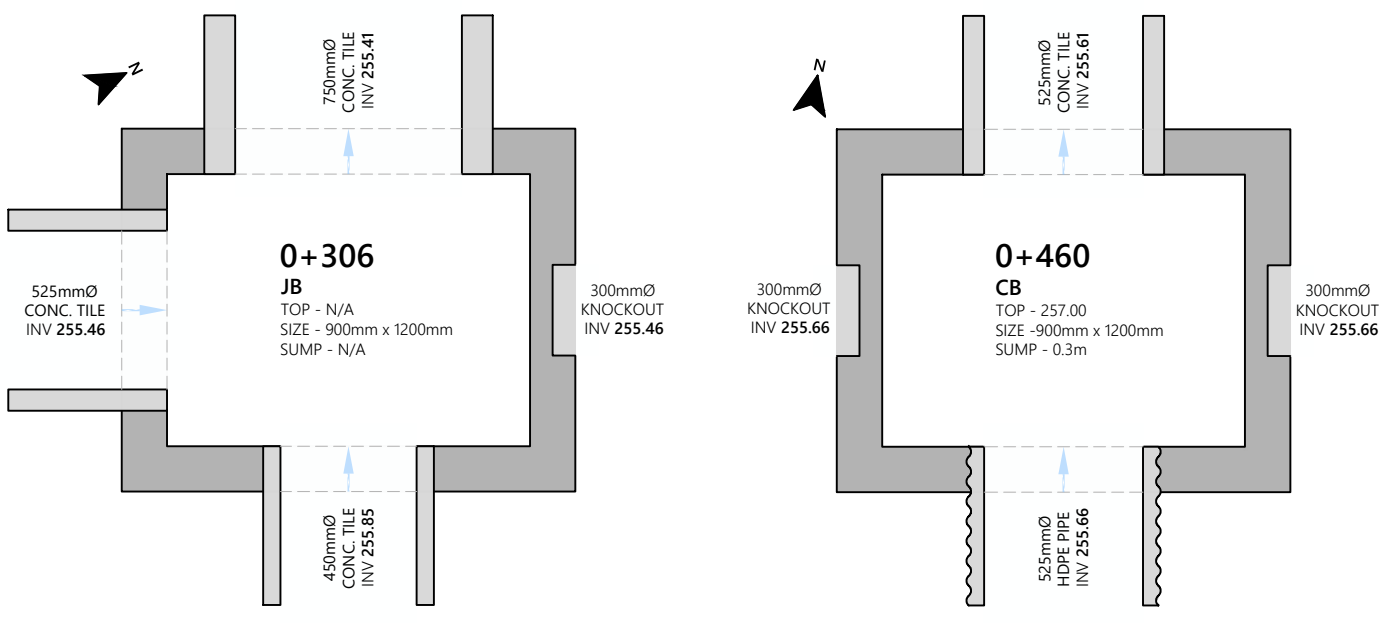
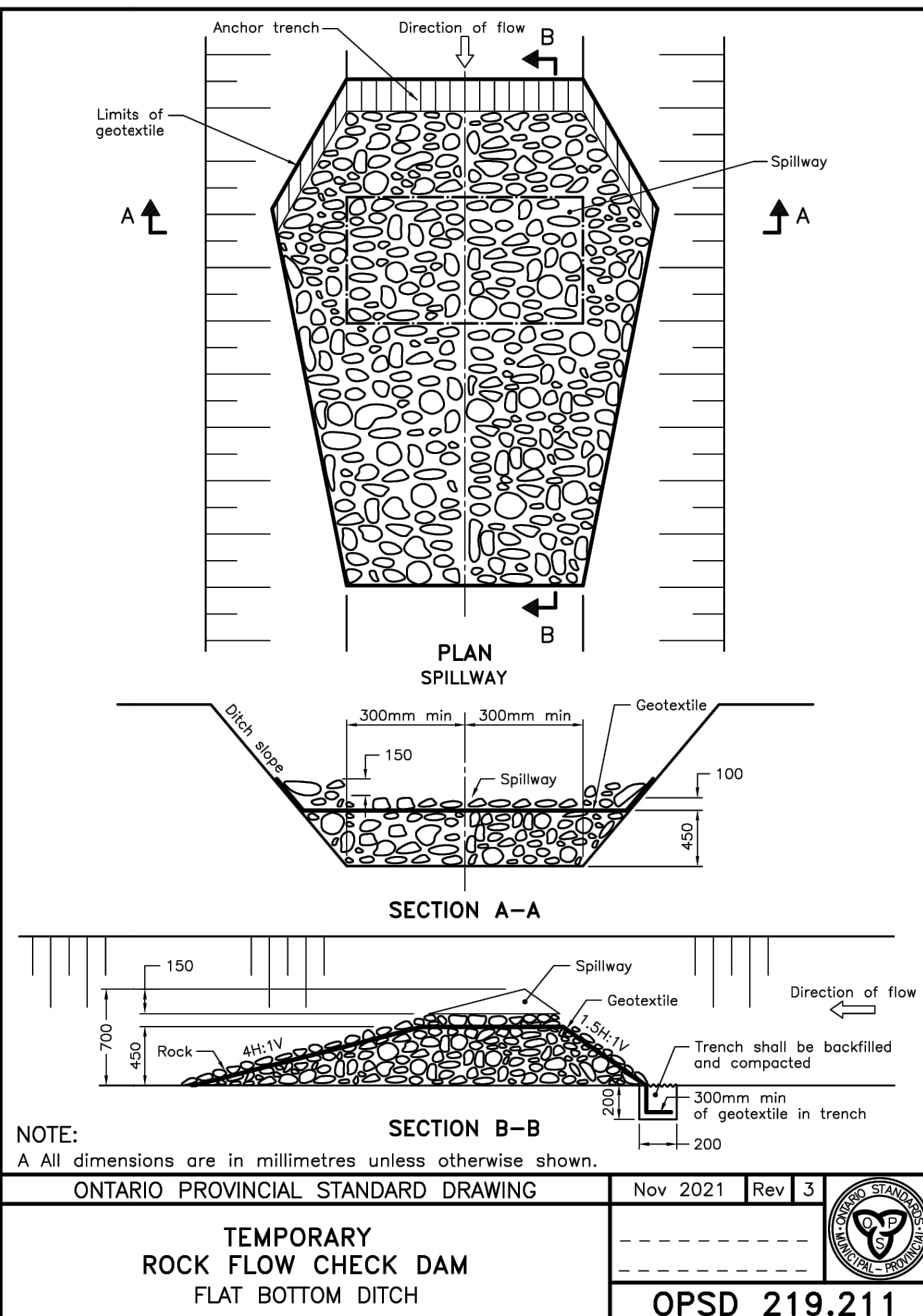
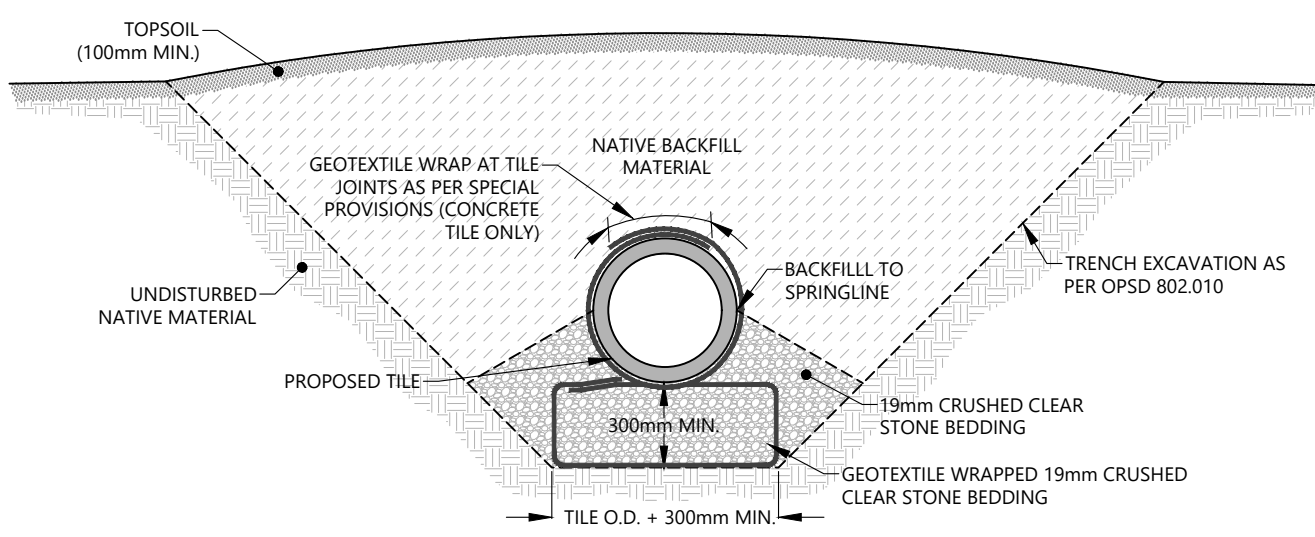
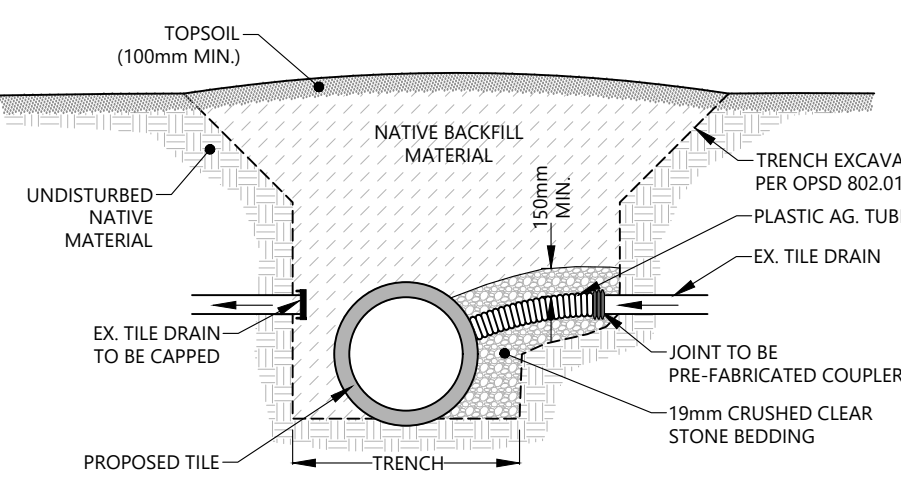
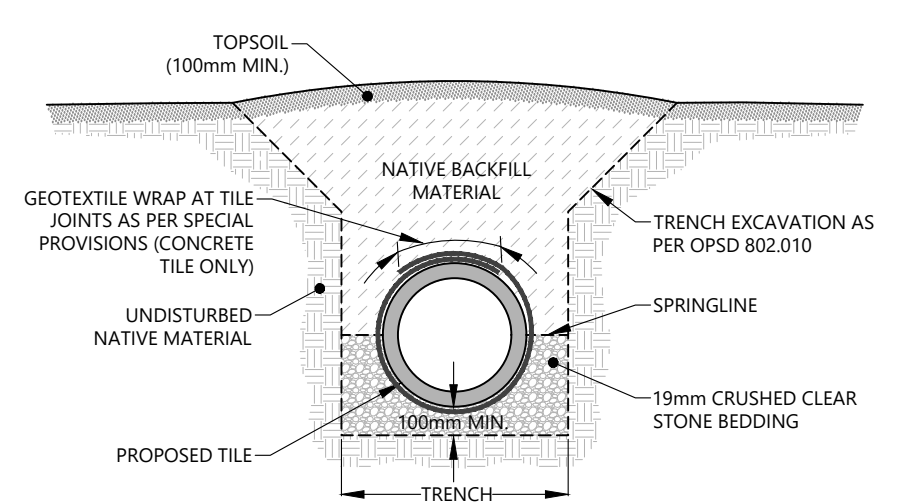
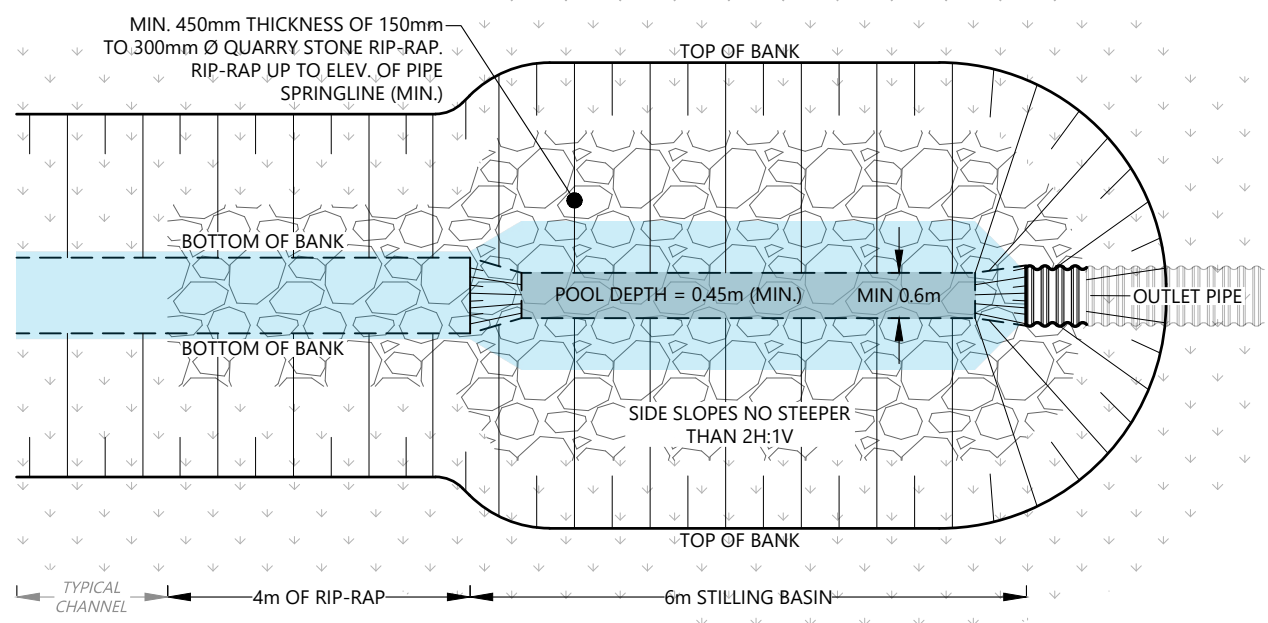
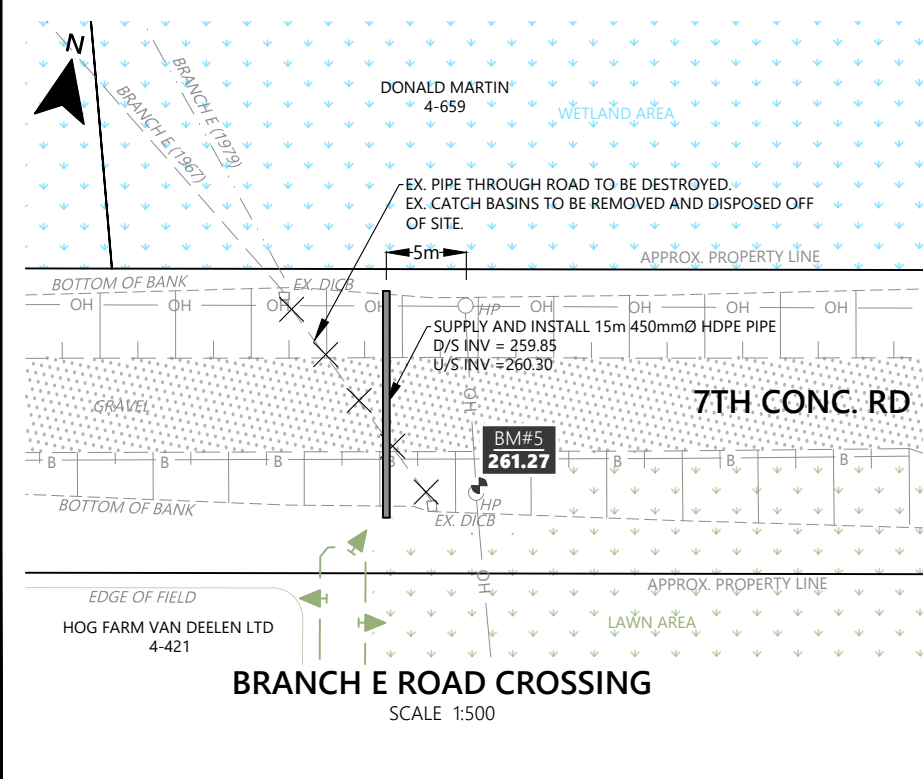
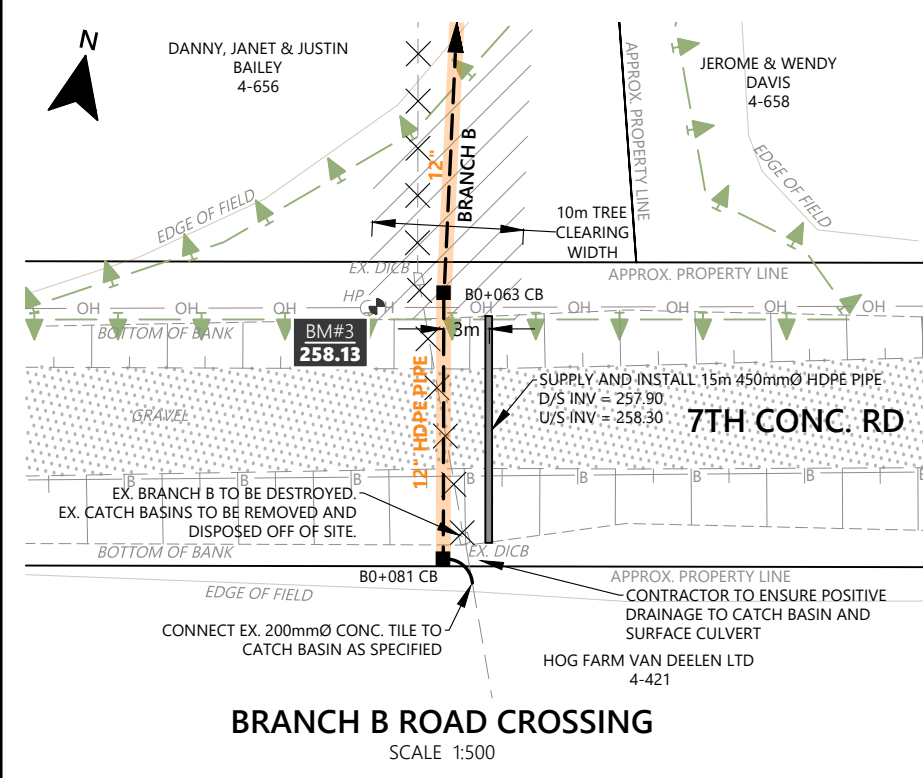
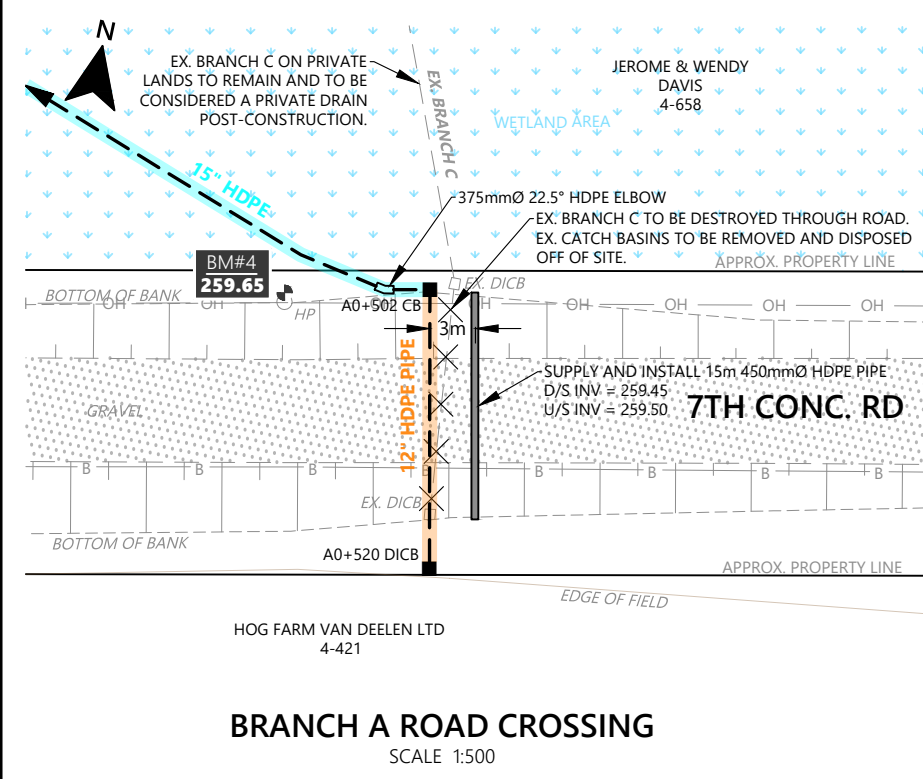
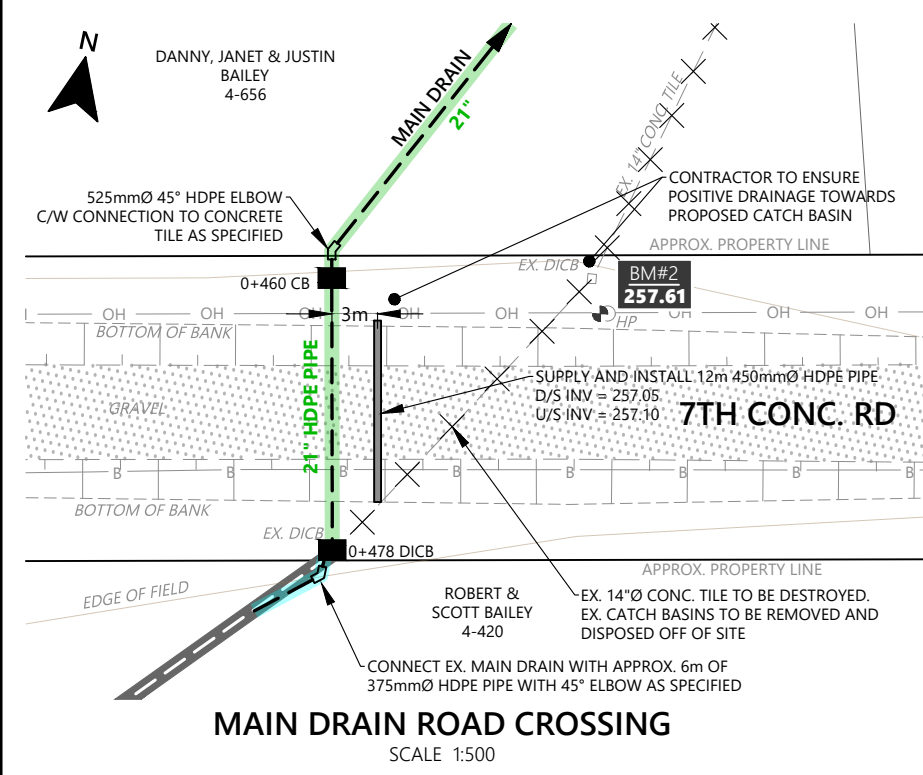

LEGEND

BENCHMARK LOCATION, NUMBER, & ELEVATION	BM#1 ELEV	TREELINE	—▲—
PR. TILE	—	FENCELINE	—X—
EX. TILE	---	EDGE OF FIELD	---
FUTURE MAINT. TILE	---	BELL LINE (APPROX. LOCATION)	—B—
EX. OPEN DRAIN	---	OVERHEAD HYDRO	—OH—
PR. SURFACE CULVERT	---	HYDRO POLE	—HP—
PR. CATCH BASIN	■		
EX. CATCH BASIN	□		



PROJECT
TERRYBERRY MUNICIPAL DRAIN IMPROVEMENT 2025

CLIENT
COUNTY OF Brant Simply Grand

ENGINEERING INC.
STREAMLINE ENGINEERING INC.

ISSUE / REVISION	DATE
FOR ON-SITE MEETING	OCT 2024
FOR INFO MEETING	NOV 2024
FOR ENGINEER'S REPORT	JAN 2025

DRAWING
DETAILS

DRAWING NO.
2 OF 3

DESIGNED: MS/CK, DRAWN: MS/CK, CHECKED: TK, PROJECT NO: 0015

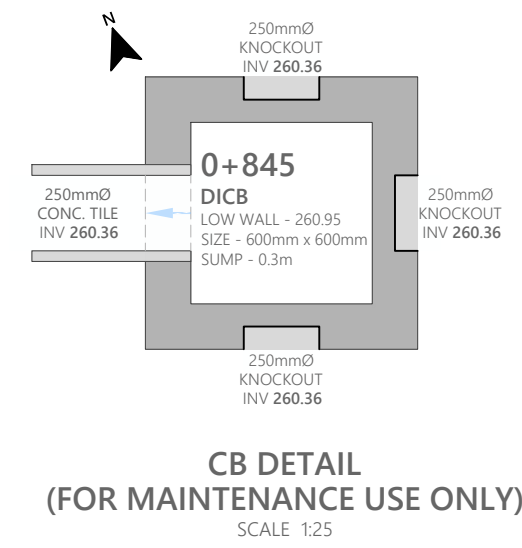
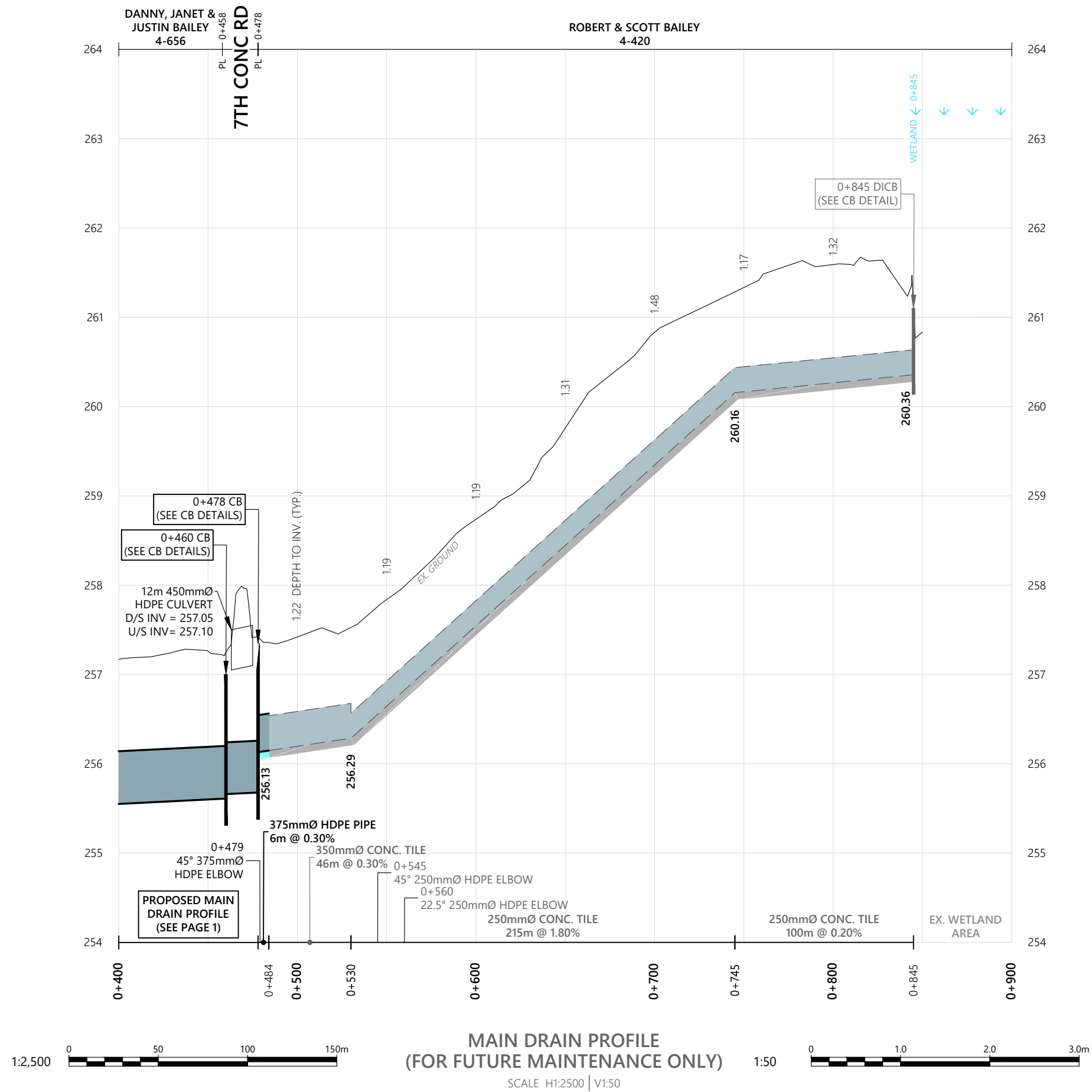

PROJECT		TERRYBERRY MUNICIPAL DRAIN IMPROVEMENT 2025	
CLIENT			
ISSUE / REVISION	DATE	DRAWING NO.	
FOR ON-SITE MEETING	OCT 2024	FOR MAINTENANCE USE ONLY	
FOR INFO MEETING	NOV 2024	3 OF 3	
FOR ENGINEER'S REPORT	JAN 2025	PROJECT NO. 0015	
DESIGNED MS/CK	DRAWN MS/CK	CHECKED TK	PROJECT NO. 0015